

SECTION "A-A"
NOT TO SCALE

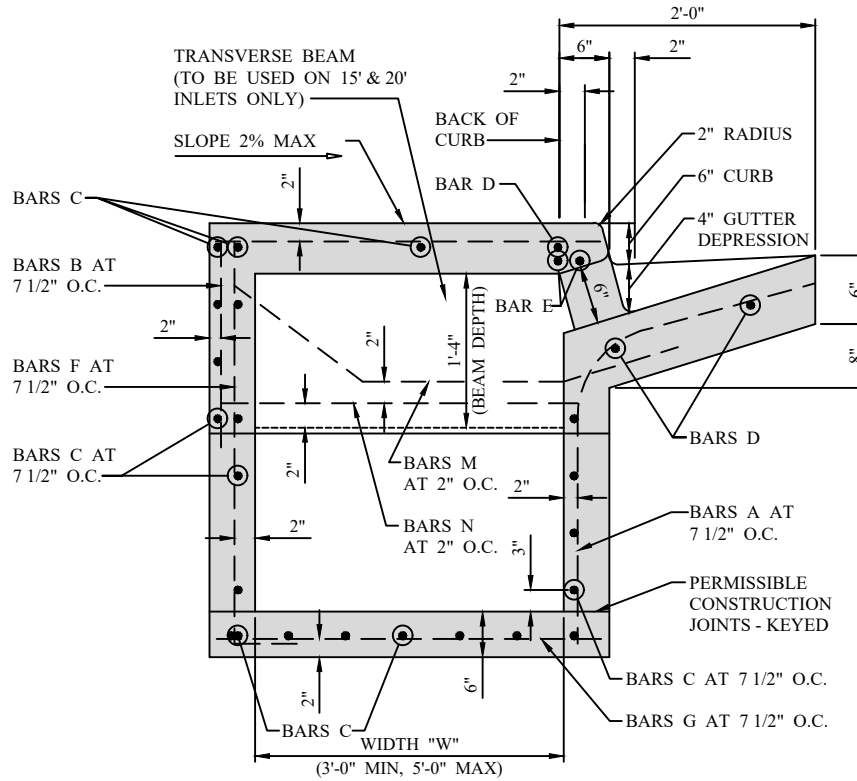

SECTION "B-B"
NOT TO SCALE

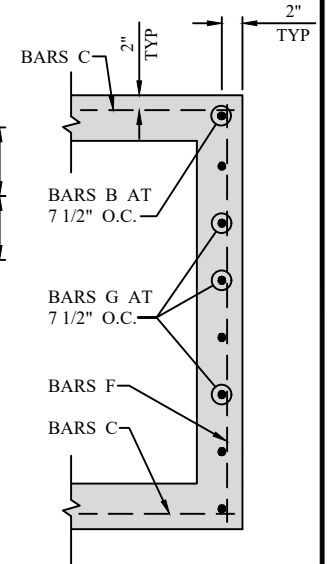

SECTION "C-C"
NOT TO SCALE

GENERAL NOTES:

1. ALL CONCRETE SHALL BE CLASS "A" CONCRETE.
2. REINFORCING BARS SHALL BE STANDARD GRADE STEEL, DEFORMED REINFORCING BARS OF A DIAMETER AND LENGTH AS SHOWN.
3. CHAMFER ALL EXPOSED CORNERS 3/4" EXCEPT WHERE OTHERWISE NOTED.
4. DIMENSIONS RELATING TO REINFORCING STEEL ARE TO CENTERS OF BARS.
5. FIELD CUT AND BEND BARS AS NECESSARY TO ACCOMMODATE STORM SEWER PIPE.
6. RING AND COVER SHALL BE APPROVED BY THE OWNER AND INSTALLED BY THE CONTRACTOR.

CITY OF SAN ANGELO

**STORM SEWER CURB INLET
CROSS-SECTION & INLET THROAT**

January 2008

S-AA-2