

STANDARD CURB & GUTTER
NOT TO SCALE

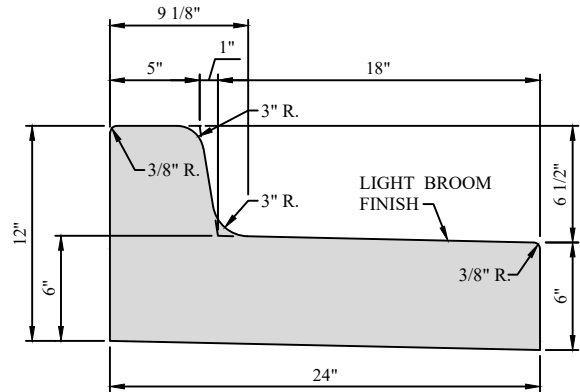

SPILL CURB AND GUTTER
NOT TO SCALE

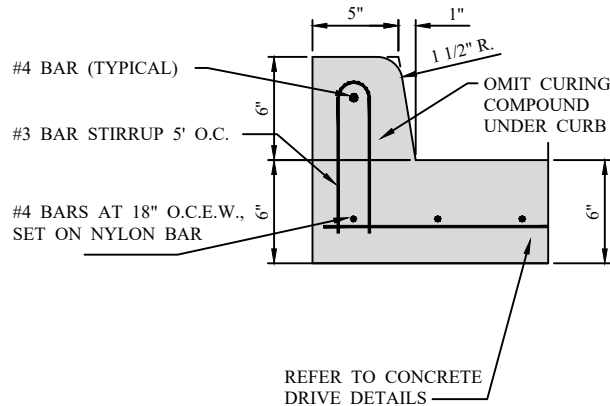

STANDARD MONOLITHIC CURB
ON CONCRETE DRIVEWAY
NOT TO SCALE

NOTES:

1. DIMENSIONS HEREIN SHOWN ARE MINIMUM REQUIRED. THE DESIGNER MAY ADJUST WIDTH ACCORDING TO THE NEED. CONCRETE FOR CURB AND GUTTER SHALL BE CLASS "A" CONCRETE EXCEPT FOR STANDARD MONOLITHIC CURB WHICH IS CLASS "P". THE USE OF MORTAR TOPPING IS OPTIONAL. IF NOT MACHINE LAID, A "MULE" FINISHING TOOL SHALL BE USED.
2. ALL TOOLED CONTRACTION JOINTS WILL BE ON 10' SPACING AT 1-1/2" MINIMUM DEPTHS. 1/2" EXPANSION JOINTS ON 50' SPACING OR AT BEGINNING OF RADII, OR AT INTERSECTIONS. LIGHT BROOM FINISH.
3. EXTRUDED CONCRETE MAY USE A MODIFIED GRADATION FOR MACHINE LAID CURB AND GUTTER AS APPROVED BY THE CITY ENGINEER.
4. IF MACHINE LAID, A MAXIMUM 1" FLARE AT THE BOTTOM IS PERMITTED.

CITY OF SAN ANGELO

CONCRETE CURB & GUTTERS

January 2008

S-T-1