

**CONCRETE DRIVEWAY APRON**  
NOT TO SCALE

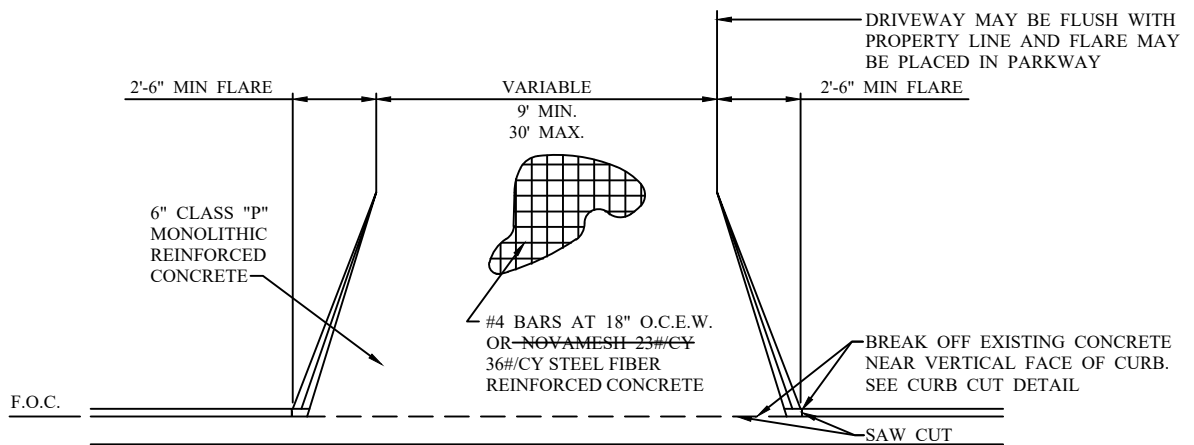

**CONCRETE DRIVEWAY APPROACH**  
(ALTERNATE)  
NOT TO SCALE

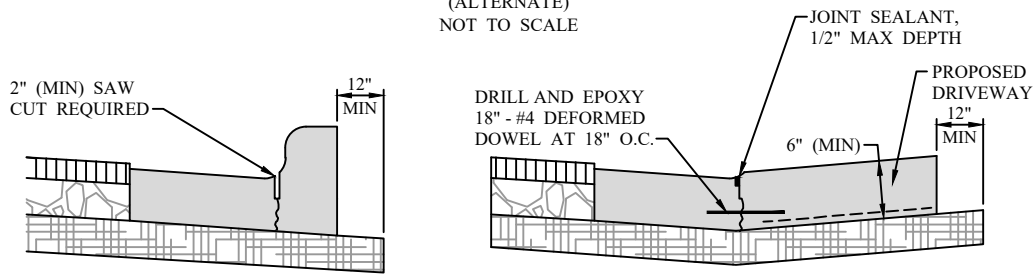

**EXISTING CURB CUT DETAIL**  
NOT TO SCALE

**NOTES:**

1. A ROUGH BROOM FINISH IS PREFERRED.
2. SLOPE OF DRIVEWAY SHALL NOT EXCEED 12:1 SLOPE.
3. WET SUBGRADE SHALL BE CORRECTED PRIOR TO PLACEMENT OF CONCRETE.
4. DRIVEWAY MAY BE FLUSH WITH THE PROPERTY LINE.

**LAP SPLICE LENGTHS:**

- #3 - 21"
- #4 - 24"

**CITY OF SAN ANGELO**

**CONCRETE DRIVEWAY APPROACHES**

January 2008 - REV September 2017

S-V-1