

4" PIPE BOLLARD

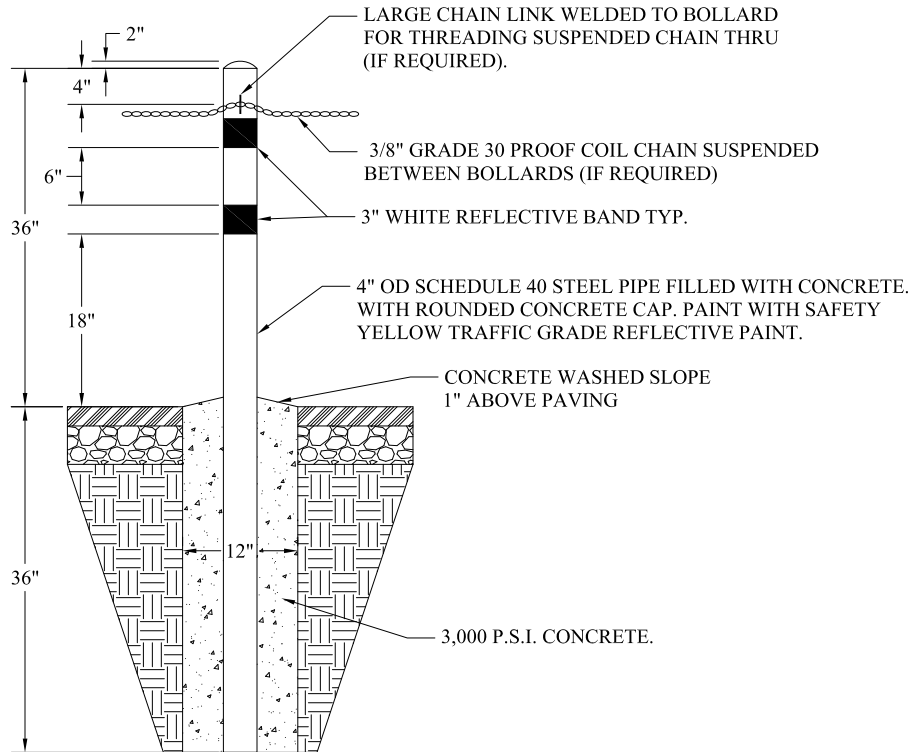

NOTES

1. VERIFY LOCATIONS OF UNDERGROUND UTILITIES BEFORE DIGGING.
2. BOLLARDS SHALL NOT BE PLACED CLOSER THAN 18" TO BACK OF CURB UNLESS OTHERWISE NOTED ON PLANS.
3. WHEN BOLLARDS ARE PLACED AS PERIMETER FOR A FACILITY, TYPICAL SPACING SHALL BE 15 FEET.
4. SUSPENDED CHAIN SHALL BE PULLED TAUGHT TO PROVIDE MINIMUM 18" CLEARANCE FROM GROUND AT LOWEST POINT.
5. TO BEGIN AND END SUSPENDED CHAIN SECURE TO LINK WELDED TO BOLLARD WITH 1/2" SCREW-TYPE QUICK LINK.
6. WHERE SUSPENDING CHAIN ACROSS DRIVEWAY FOR A GATE, WELD ONE SIDE SECURE TO BOLLARD WITH SUFFICIENT LENGTH OF CHAIN TO REACH AND LOCK TO A 12" PIECE OF CHAIN WELDED TO BOLLARD ON OTHER SIDE OF DRIVEWAY.

CITY OF SAN ANGELO

4" PIPE BOLLARD

JUNE 2016

W-BOL