

CITY OF SAN ANGELO, TEXAS  
TOM GREEN COUNTY, TEXAS

PROJECT NO. 2019-11-634  
PLANS OF PROPOSED  
GSB-FRICTION SEAL SURFACE TREATMENT -  
2020  
"FINAL SUBMITTAL"  
MARCH, 2020

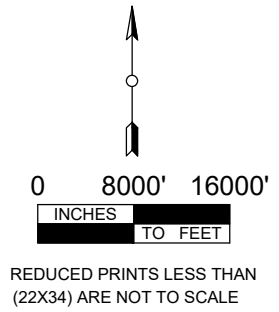

CITY OF SAN ANGELO  
ENGINEERING SERVICES  
CITY HALL ANNEX  
301 W. BEAUREGARD AVE.  
SAN ANGELO, TX. 76903  
(325)657-4201  
WWW.COSBAIX.US

SHEET	DESCRIPTION
C-000	COVER SHEET
C-001	GENERAL NOTES
C-002	STRIPING DETAILS
C-400	GSB FRICTION SEAL - SECTION 1
C-401	GSB FRICTION SEAL - SECTION 2
C-402	GSB FRICTION SEAL - SECTION 3

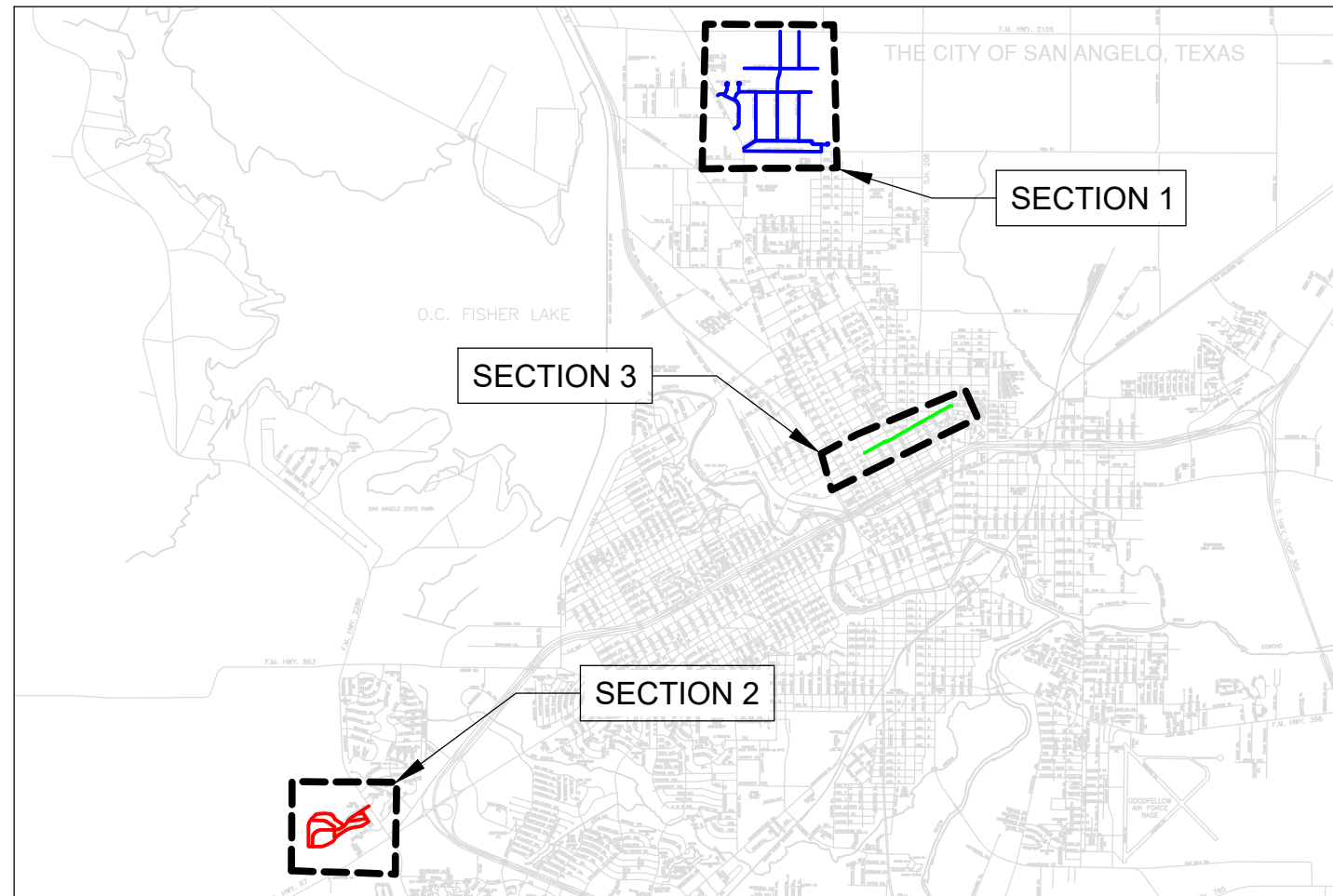

CITY MANAGER: DANIEL VALENZUELA  
MAYOR: BRENDA GUNTER

COUNCIL MEMBERS:

- |                      |                      |
|----------------------|----------------------|
| SMD1 - TOMMY HIEBERT | SMD4 - LUCY GONZALES |
| SMD2 - TOM THOMPSON  | SMD5 - LANE CARTER   |
| SMD3 - HARRY THOMAS  | SMD6 - BILLIE DEWITT |

PUBLIC WORKS DEPARTMENT  
ENGINEERING SERVICES DIVISION  
CITY ENGINEER: LANCE OVERSTREET, P.E.

NO	DESCRIPTION	DATE

The Seal appearing on this document was authorized by Ricky L. Overstreet, P.E. 121782 on: March 9, 2020

SCALE: 1"=8000'	ES-X-XX
DATE: 03/01/2020	COVER SHEET
ARCHIVE NO: ####	COSA - GSB FRICTION SEAL SURFACE TREATMENT
SHEET NO. C-000	PROJECT NO: 2019-11-634
1 OF 9	DESIGN BY: MG DRAWN BY: MG



DISCLAIMER: The use of this standard is governed by the "Texas Engineering Practice Act". No warranty of any kind is made by TxDOT for any purpose whatsoever. TxDOT assumes no responsibility for the conversion of this standard to other formats or for incorrect results or damages resulting from its use.

DATE:  
FILE:

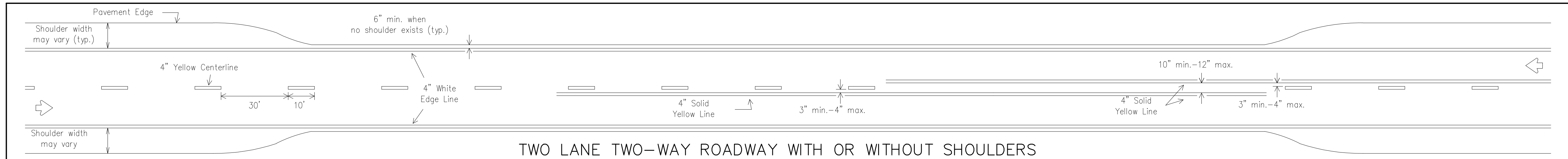

TWO LANE TWO-WAY ROADWAY WITH OR WITHOUT SHOULDERS

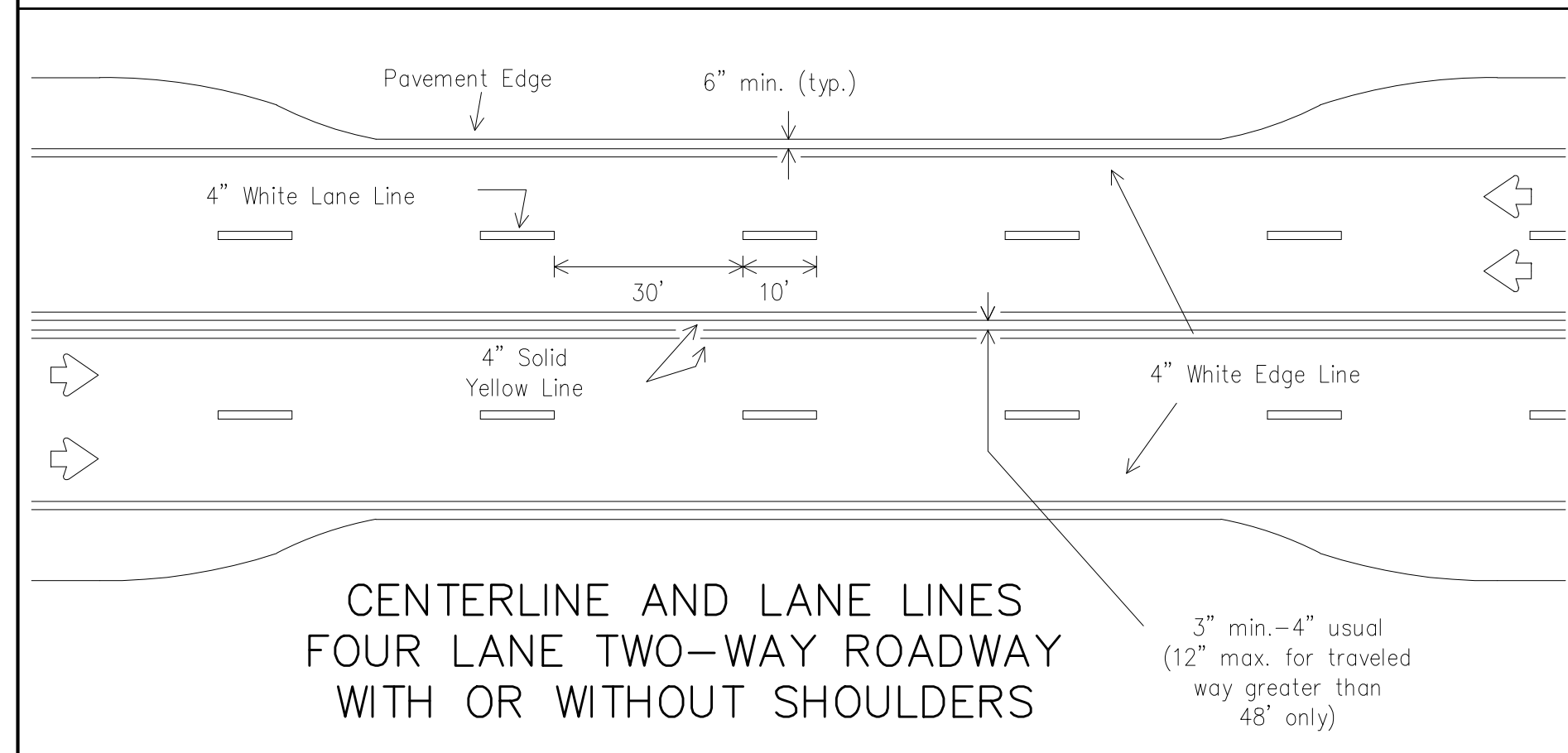

CENTERLINE AND LANE LINES  
FOUR LANE TWO-WAY ROADWAY  
WITH OR WITHOUT SHOULDERS

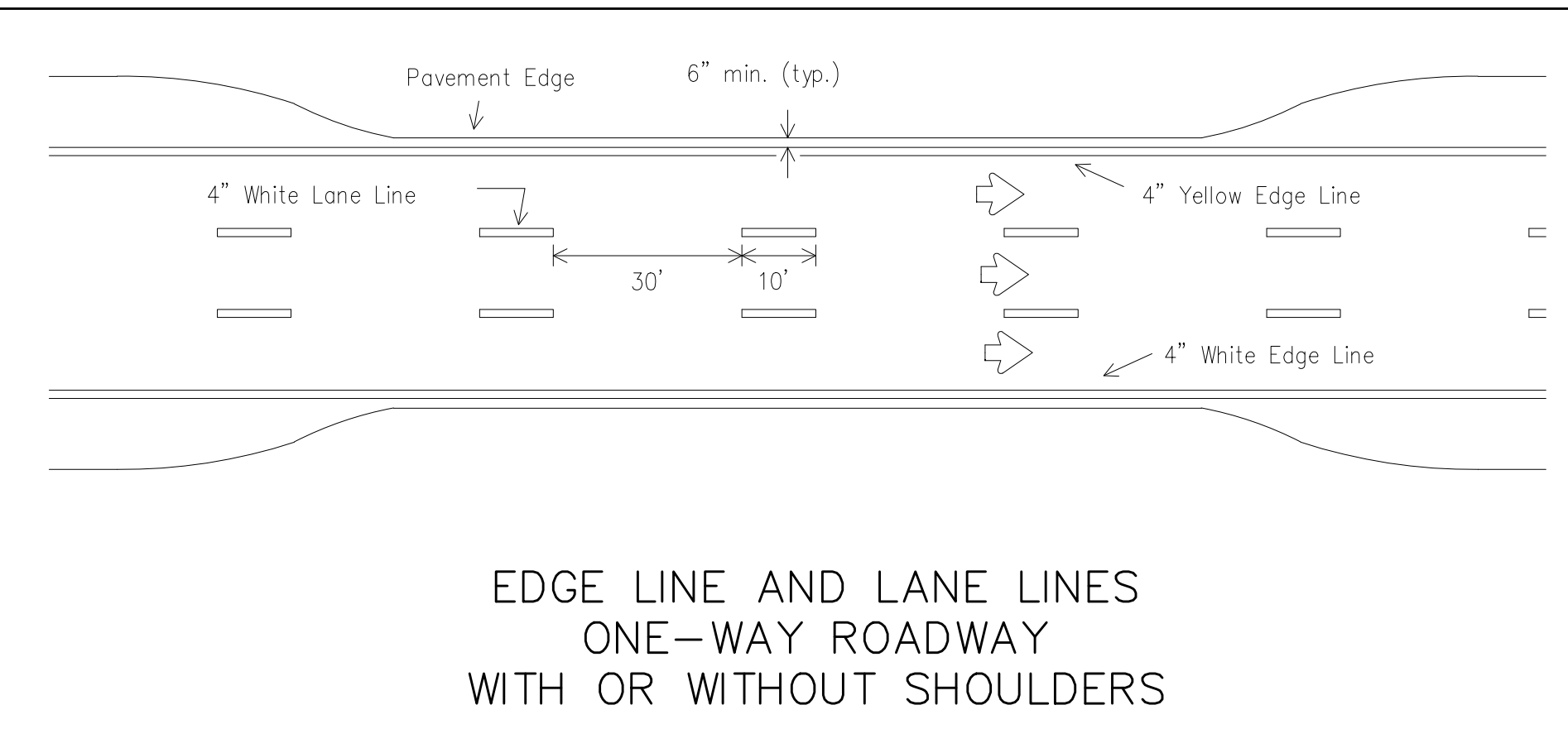

EDGE LINE AND LANE LINES  
ONE-WAY ROADWAY  
WITH OR WITHOUT SHOULDERS

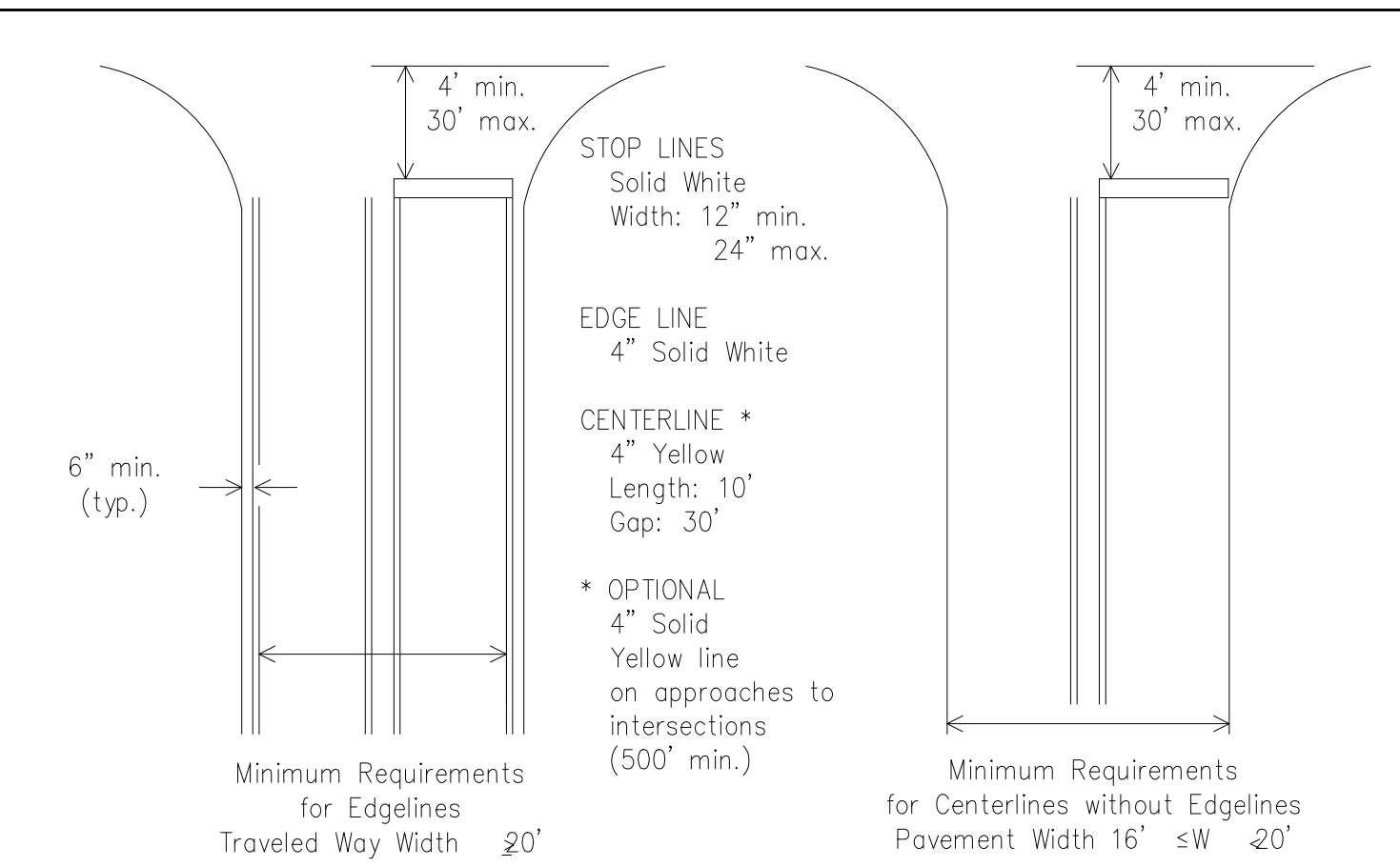

GUIDE FOR PLACEMENT OF STOP LINES,  
EDGE LINE & CENTERLINE  
Based on Traveled Way and Pavement Widths for Undivided Highways

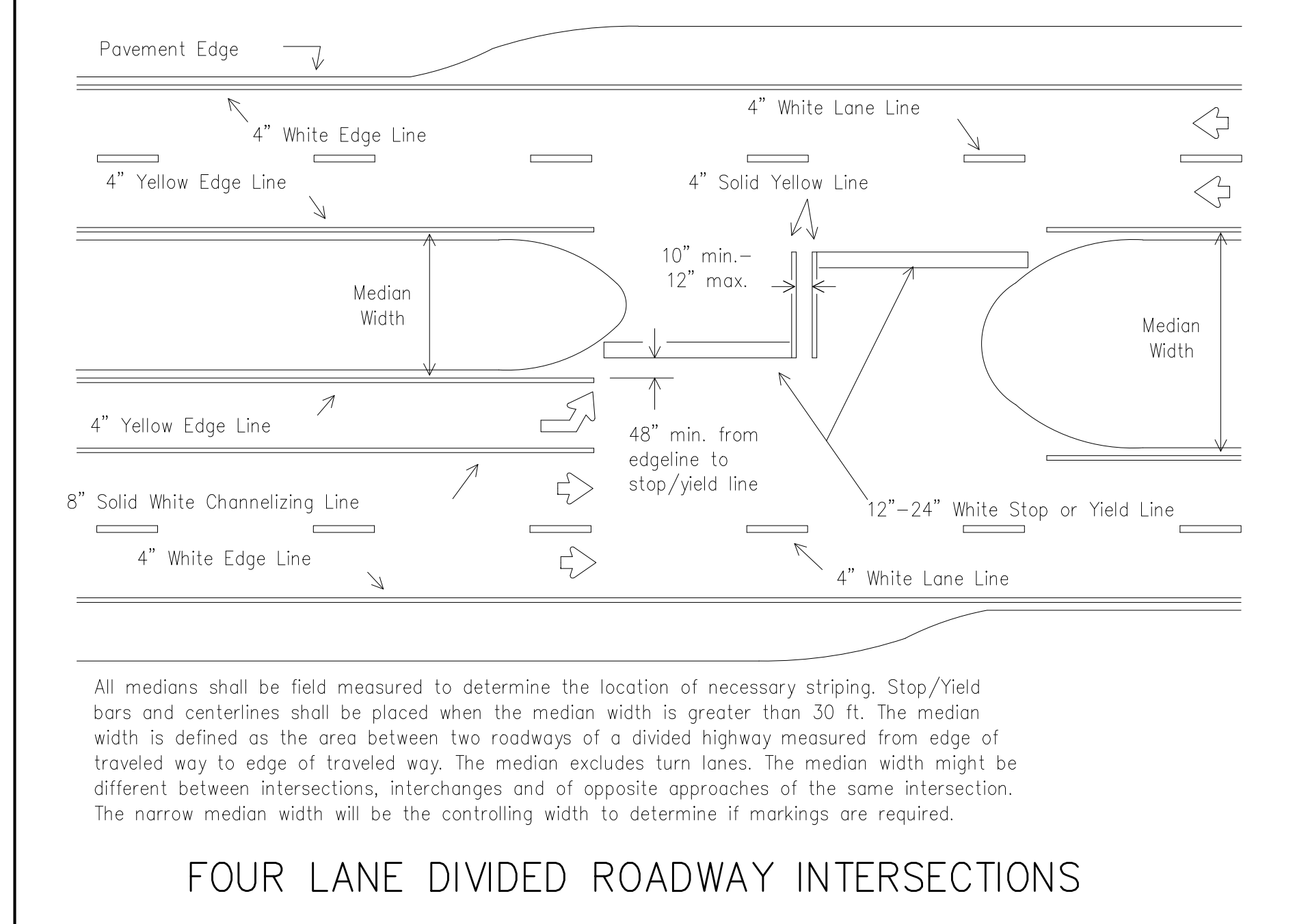

FOUR LANE DIVIDED ROADWAY INTERSECTIONS

GENERAL NOTES

1. Edgeline striping shall be as shown in the plans or as directed by the Engineer. The edgeline should typically be placed a minimum of 6 inches from the edge of pavement. This distance may vary due to pavement raveling or other conditions. Edgelines are not required in curb and gutter sections of roadways.
2. The traveled way includes only that portion of the roadway used for vehicular travel and not the parking lanes, sidewalks, berms and shoulders. The traveled ways shall be measured from the inside of edgeline to inside of edgeline of a two lane roadway.

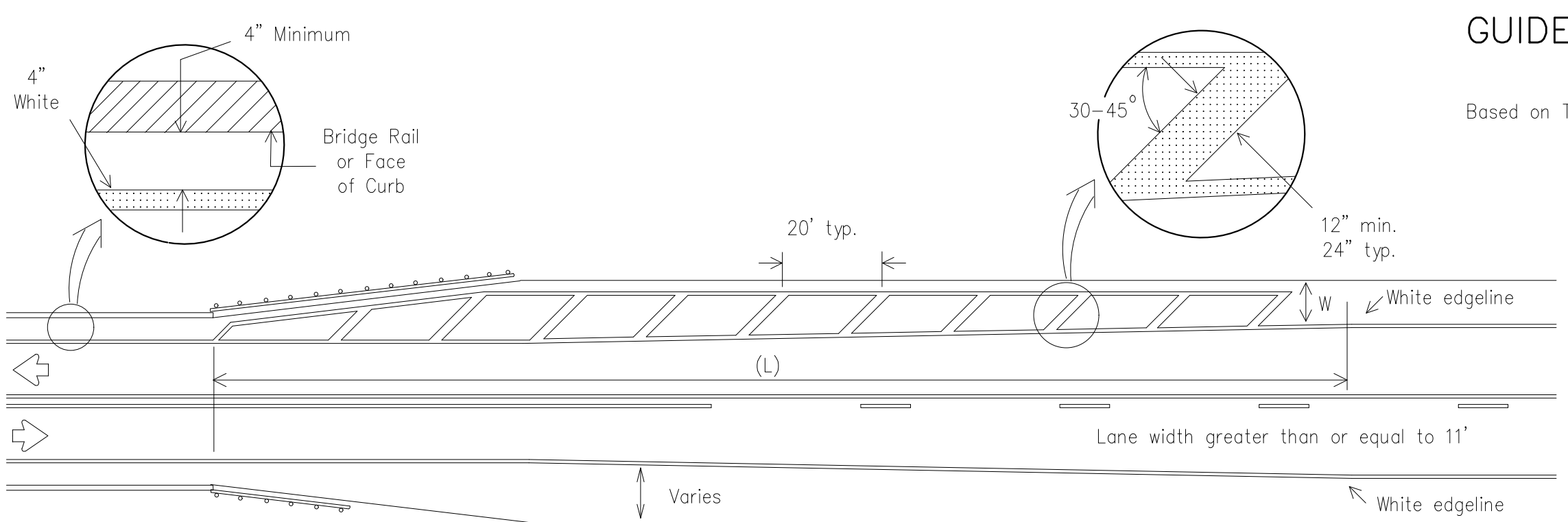

NOTES:

1. No-passing zone on bridge approach is optional but if used, it shall be a minimum 500 feet long.
2. For crosshatching length (L) see Table 1.
3. The width of the offset (W) and the required crosshatching width is the full shoulder width in advance of the bridge.
4. The crosshatching is not required if delineators or barrier reflectors are used along the structure.
5. For guard fence details, refer elsewhere in the plans.

ROADWAYS WITH REDUCED SHOULDER  
WIDTHS ACROSS BRIDGE OR CULVERT

MATERIAL SPECIFICATIONS	
PAVEMENT MARKERS (REFLECTORIZED)	DMS-4200
EPOXY AND ADHESIVES	DMS-6100
BITUMINOUS ADHESIVE FOR PAVEMENT MARKERS	DMS-6130
TRAFFIC PAINT	DMS-8200
HOT APPLIED THERMOPLASTIC	DMS-8220
PERMANENT PREFABRICATED PAVEMENT MARKINGS	DMS-8240

All pavement marking materials shall meet the required Departmental Material Specifications as specified by the plans.

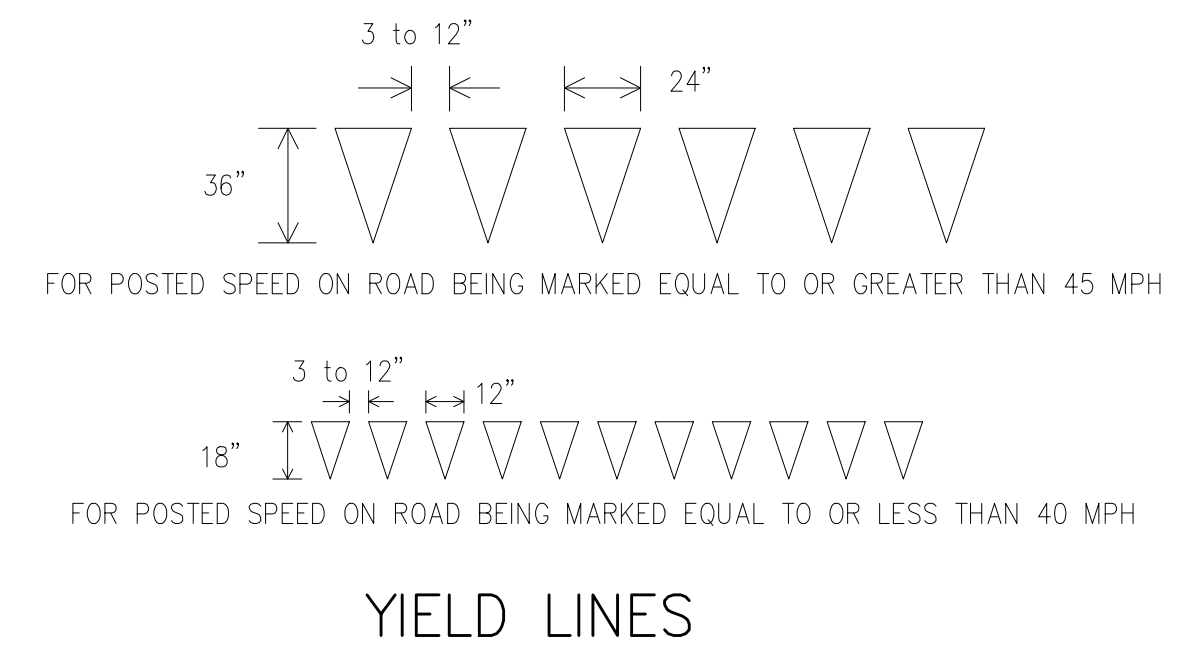

YIELD LINES

TABLE 1 - TYPICAL LENGTH (L)

Posted Speed	Formula
≤ 40	$L = \frac{WS^2}{60}$
≥ 45	$L = WS$

\* 85th Percentile Speed may be used on roads where traffic speeds normally exceed the posted speed limit. Crosshatching length should be rounded up to nearest 5 foot increment.  
L=Length of Crosshatching (FT.) W=Width of Offset (FT.)  
S=Posted Speed (MPH)

EXAMPLES:

An 8 foot shoulder in advance of a bridge reduces to 4 feet on a 70 MPH roadway. The length of the cross-hatching should be:  
 $L = 8 \times 70 = 560$  ft.  
A 4 foot shoulder in advance of a bridge reduces to 2 feet on a 40 MPH roadway. The length of the cross-hatching should be:  
 $L = 4(40) \div 60 = 106.67$  ft. rounded to 110 ft.



TYPICAL STANDARD  
PAVEMENT MARKINGS

PM(1)-12

© TxDOT November 1978	DN: TxDOT	CK: TxDOT	DW: TxDOT	OK: TxDOT
REVISIONS	CONT	SECT	JOB	HIGHWAY
8-95 2-12				
5-00				
8-00				
3-03				
	DIST	COUNTY	SHEET NO.	

22A

CITY OF SAN ANGELO  
ENGINEERING SERVICES  
CITY HALL ANNEX  
301 W. BEAUREGARD AVE.  
SAN ANGELO, TX. 76903  
(325)867-4201  
www.cosatx.us

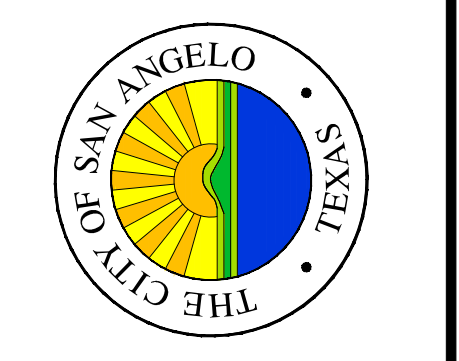

NO	DESCRIPTION	DATE

The Seal appearing on this plan is the official seal of the City of San Angelo, Texas, by Ricky L. Overstreet, P.E. 12/7/82 on: March 9, 2020

ES-X-XX	TXDOT TSPM PM(1)-12	DESIGN BY: MG	DRAWN BY: MG
	2020 GSB-FRICTION SEAL		
	PROJECT NO: 2019-11-634		

SCALE: N.T.S.	DATE: 3/1/2020	ARCHIVE NO: #####	SHEET NO. C-002
---------------	----------------	-------------------	-----------------

DISCLAIMER: The use of this standard is governed by the "Texas Engineering Practice Act". No warranty of any kind is made by TxDOT for any purpose whatsoever. TxDOT assumes no responsibility for the conversion of this standard to other formats or for incorrect results or damages resulting from its use.

DATE:  
FILE:

### REFLECTIVE RAISED PAVEMENT MARKERS FOR VEHICLE POSITIONING GUIDANCE

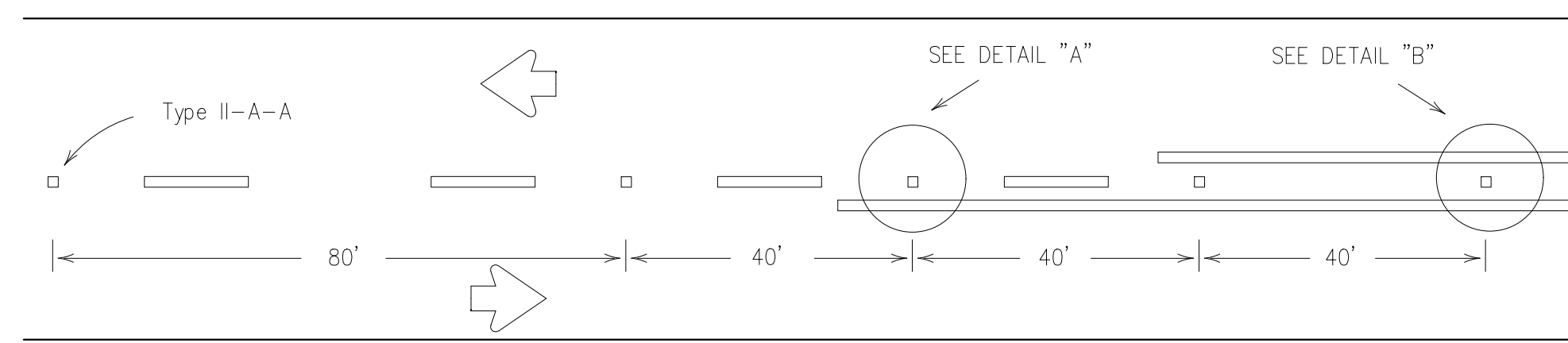

CENTERLINE FOR ALL TWO LANE ROADWAYS

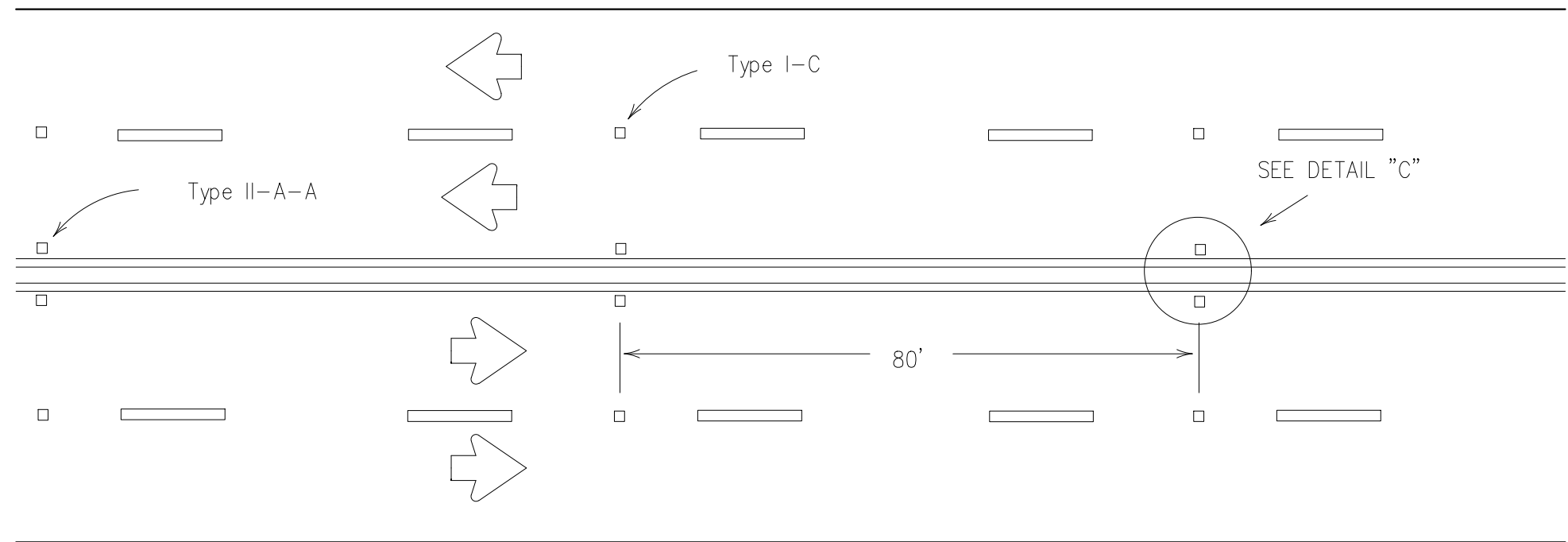

CENTERLINE & LANE LINES FOR FOUR LANE TWO-WAY HIGHWAYS

Raised pavement marker Type I-C, clear face toward normal traffic, shall be placed on 80-foot centers.

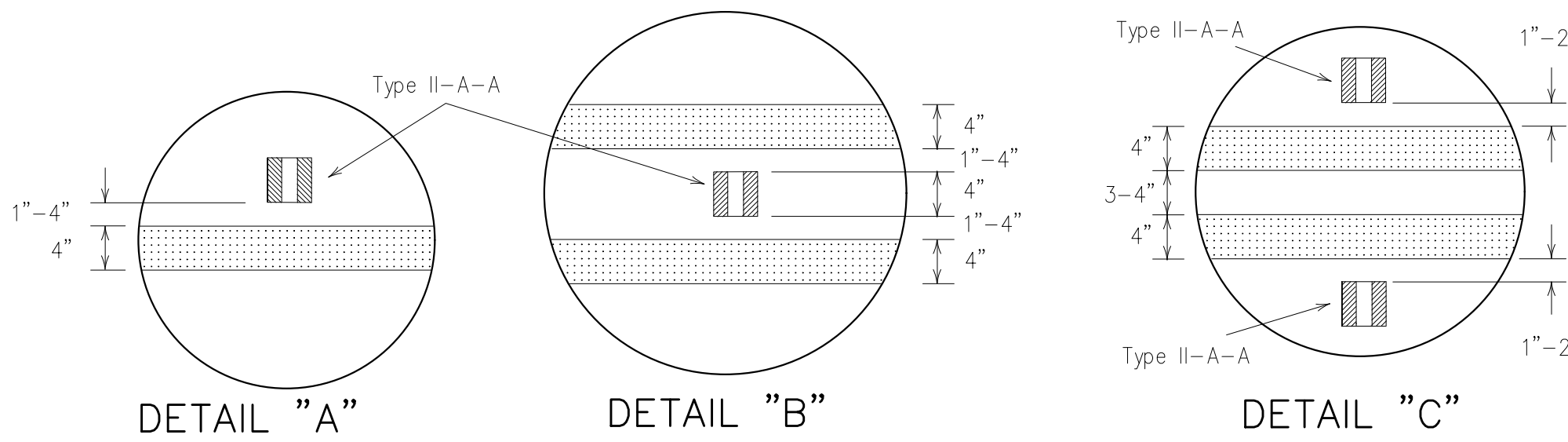

DETAIL "A"

DETAIL "B"

DETAIL "C"

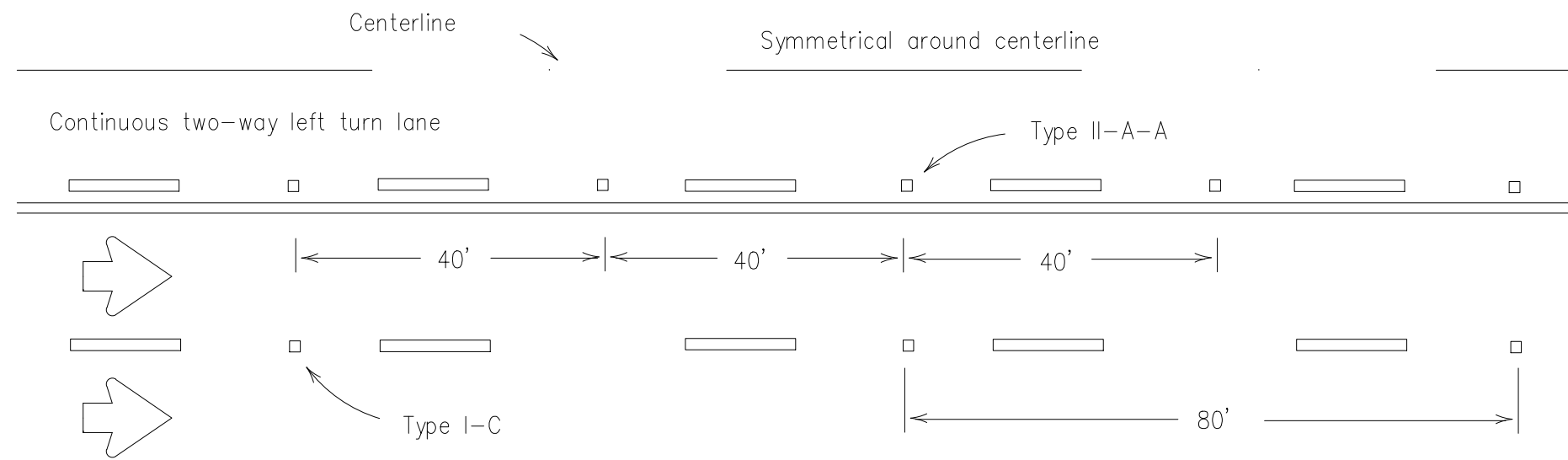

CENTERLINE AND LANE LINES FOR TWO-WAY LEFT TURN LANE

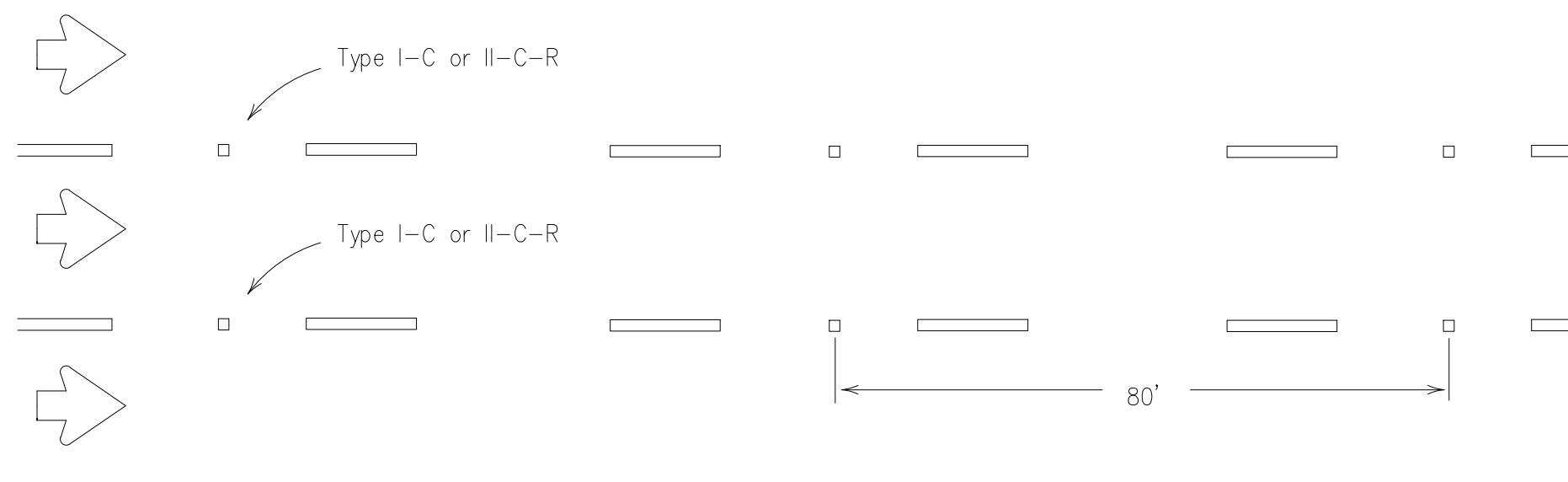

LANE LINES FOR ONE-WAY ROADWAY (NON-FREEWAY FACILITIES)

Raised pavement markers Type II-C-R shall have clear face toward normal traffic and red face toward wrong-way traffic.

MATERIAL SPECIFICATIONS	
PAVEMENT MARKERS (REFLECTORIZED)	DMS-4200
EPOXY AND ADHESIVES	DMS-6100
BITUMINOUS ADHESIVE FOR PAVEMENT MARKERS	DMS-6130
TRAFFIC PAINT	DMS-8200
HOT APPLIED THERMOPLASTIC	DMS-8220
PERMANENT PREFABRICATED PAVEMENT MARKINGS	DMS-8240

All pavement marking materials shall meet the required Departmental Material Specifications as specified by the plans.

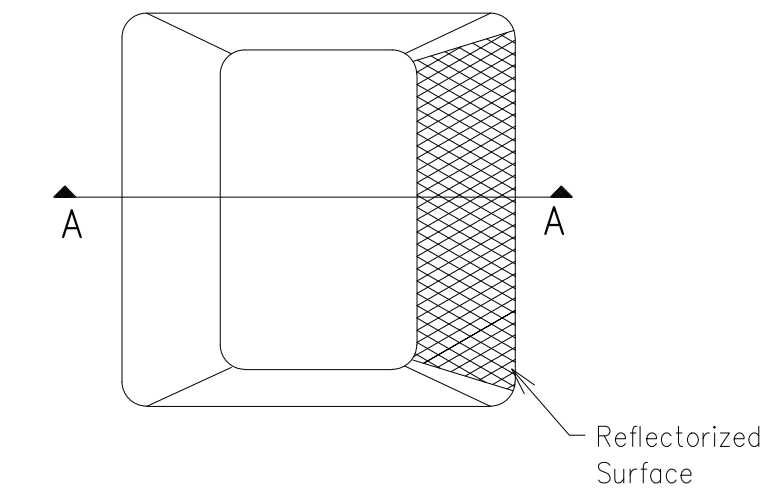

Type I (Top View)

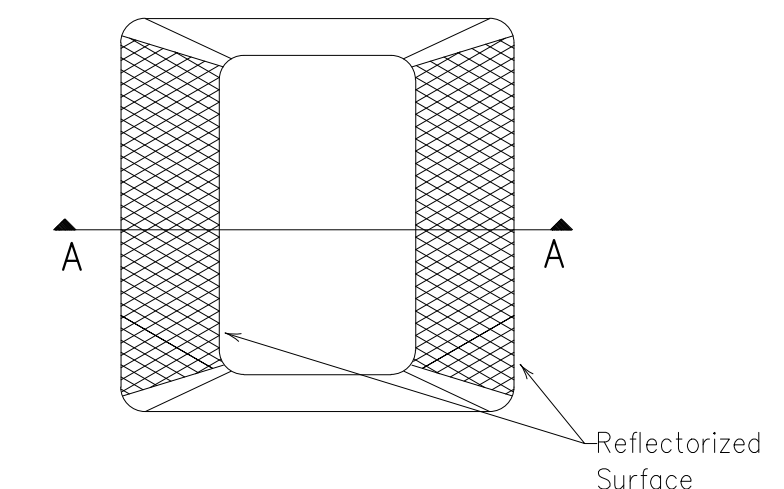

Type II (Top View)

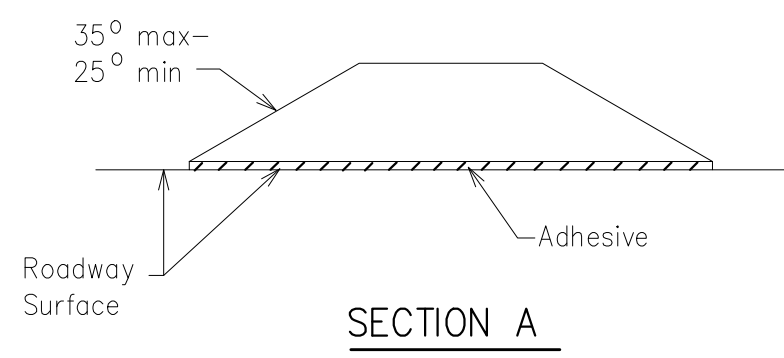

SECTION A

RAISED PAVEMENT MARKERS

- GENERAL NOTES**
- All raised pavement markers placed in broken lines shall be placed in line with and midway between the stripes.
  - On concrete pavements the raised pavement markers should be placed to one side of the longitudinal joints.

Texas Department of Transportation  
Traffic Operations Division

### POSITION GUIDANCE USING RAISED MARKERS REFLECTORIZED PROFILE MARKINGS

PM(2)-12

©TxDOT April 1977	DN: TxDOT	CK: TxDOT	DW: TxDOT	CK: TxDOT
REVISIONS	CONT	SECT	JOB	HIGHWAY
4-92 2-10				
5-00 2-12				
8-00			COUNTY	SHEET NO.
2-08				
22B				

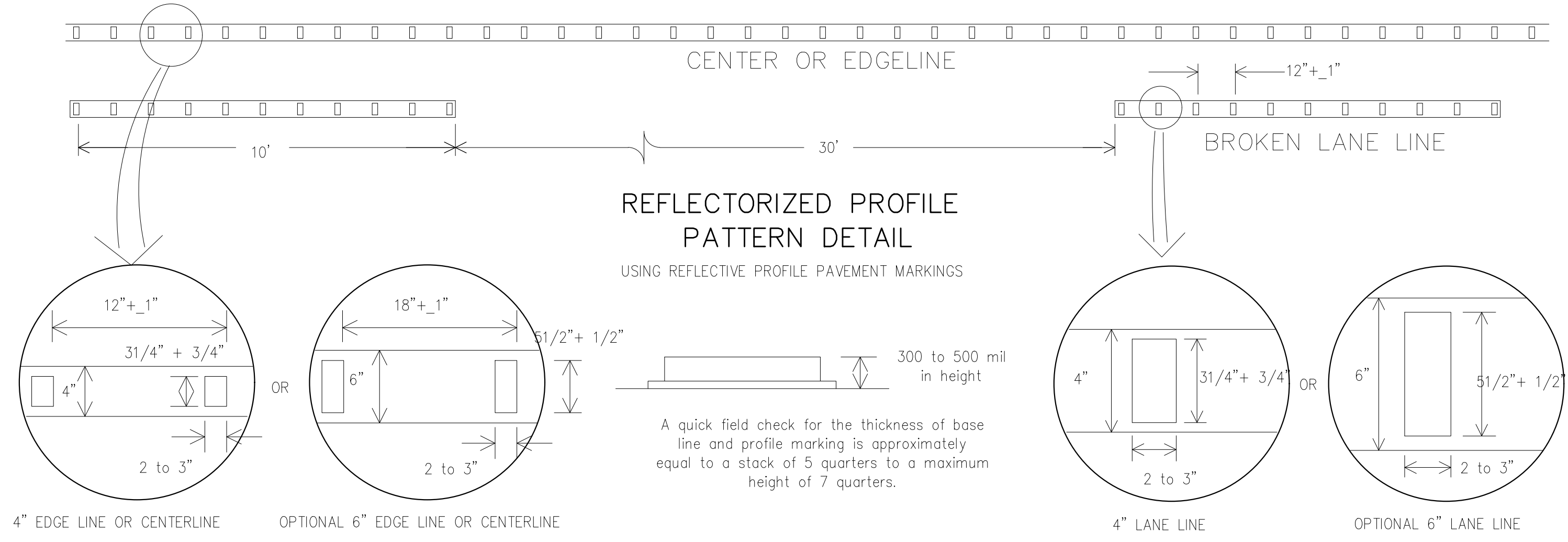

REFLECTORIZED PROFILE PATTERN DETAIL USING REFLECTIVE PROFILE PAVEMENT MARKINGS

**NOTE:**  
Profile markings shall not be placed on roadways with a posted speed limit of 45 MPH or less.

CITY OF SAN ANGELO  
ENGINEERING SERVICES  
CITY HALL ANNEX  
301 W. BEAUREGARD AVE.  
SAN ANGELO, TX 76903  
(325)657-4201  
www.cosatx.us

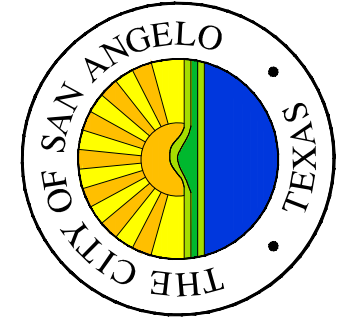

DATE	DESCRIPTION	NO

The Seal appearing on this drawing was prepared by Rick L. Overstreet, P.E. 121782 on March 9, 2020

ES-X-XX	TXDOT TSPM PM(2)-12	DESIGN BY: MG	DRAWN BY: MG
	2020 GSB-FRICTION SEAL		
	PROJECT NO: 2019-11-634		

SCALE: N.T.S.	DATE: 3/1/2020	ARCHIVE NO: #####	SHEET NO. C-003
---------------	----------------	-------------------	-----------------

DISCLAIMER: The use of this standard is governed by the "Texas Engineering Practice Act". No warranty of any kind is made by TxDOT for purposes whatsoever, and TxDOT assumes no responsibility for the correctness of this standard to other formats or for incorrect results or damages resulting from its use.

DATE:  
FILE:

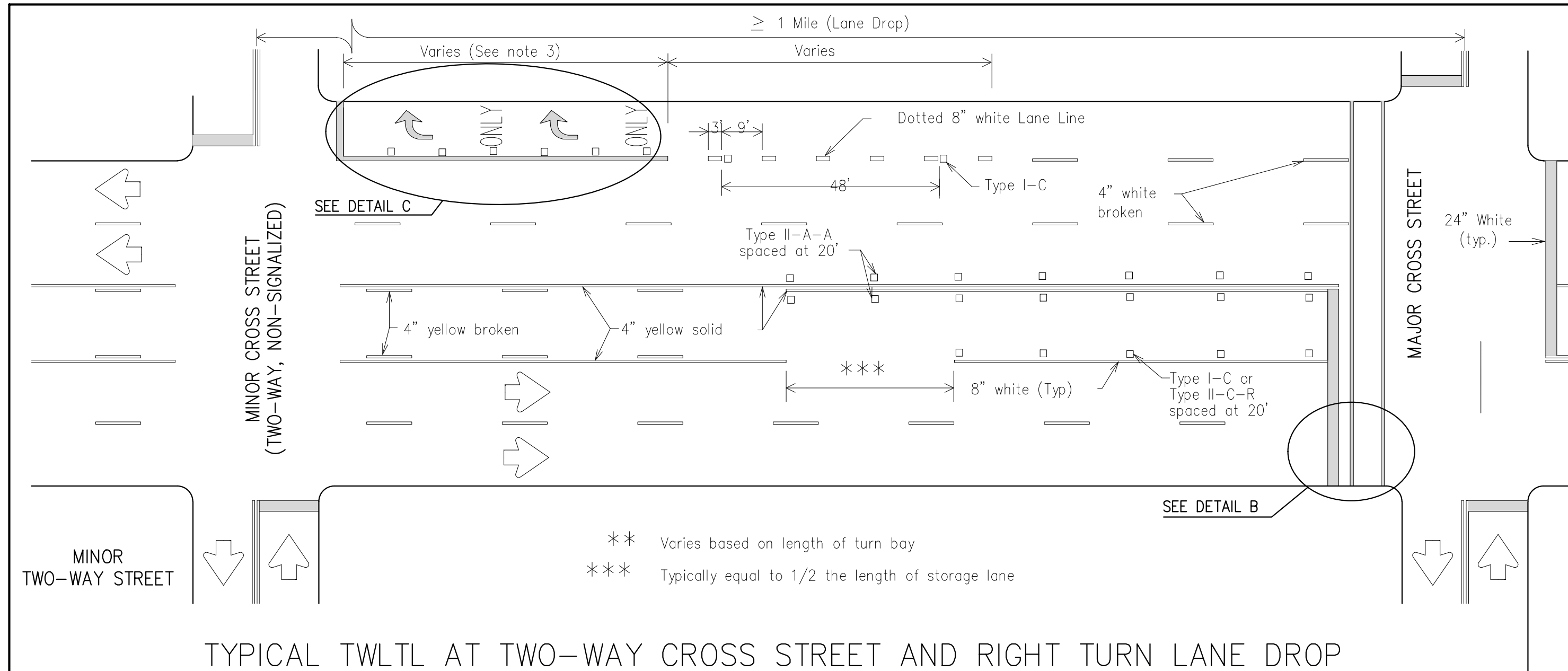

TYPICAL TWLTL AT TWO-WAY CROSS STREET AND RIGHT TURN LANE DROP

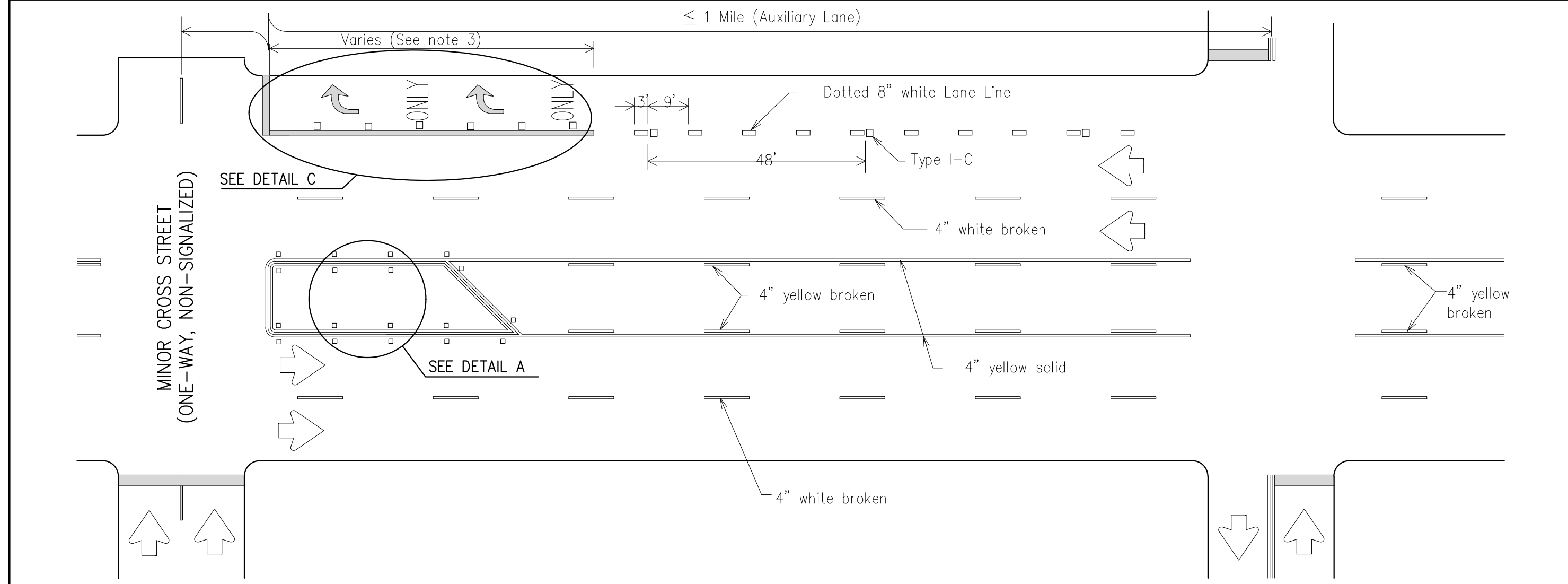

TYPICAL TWLTL AT ONE-WAY STREET AND RIGHT TURN AUXILIARY LANE

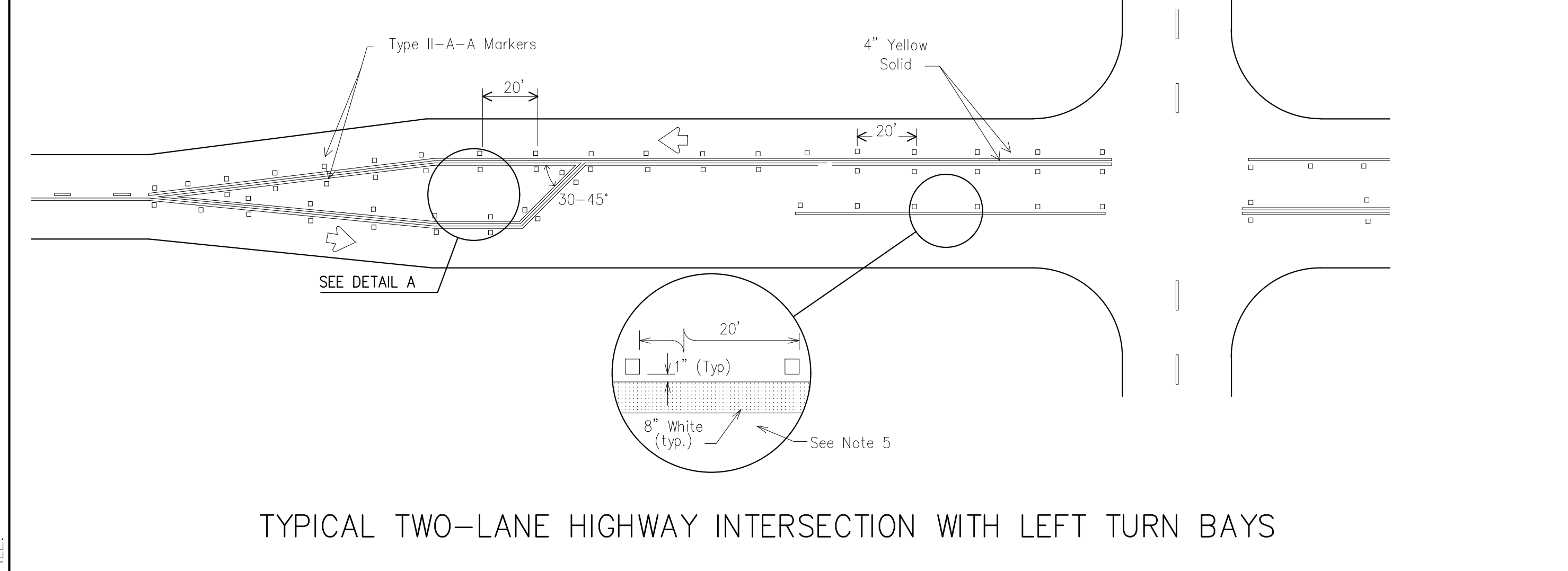

TYPICAL TWO-LANE HIGHWAY INTERSECTION WITH LEFT TURN BAYS

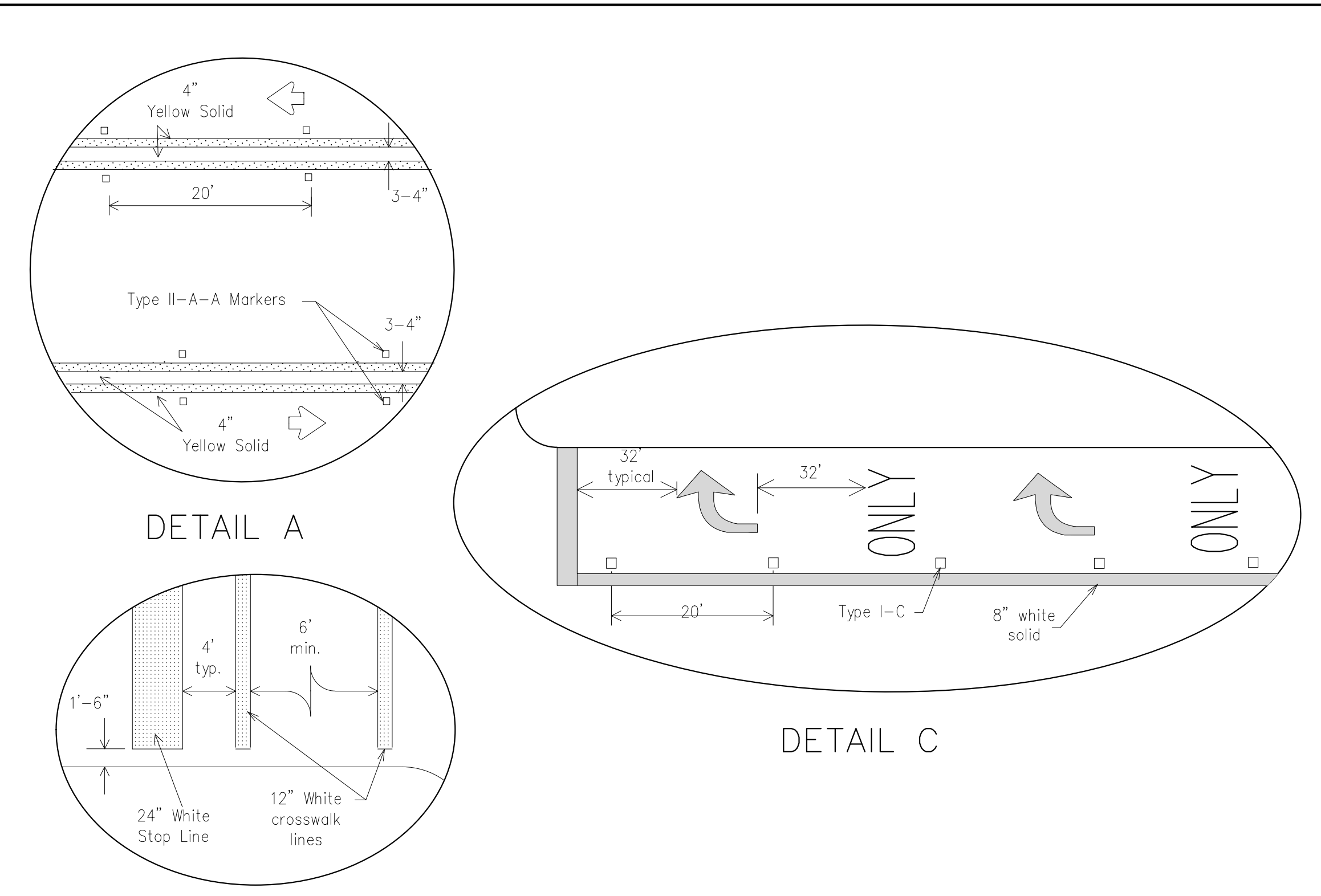

Final placement of Stop Bar and Crosswalk shall be approved by the Engineer in the field.

MATERIAL SPECIFICATIONS	
PAVEMENT MARKERS (REFLECTORIZED)	DMS-4200
EPOXY AND ADHESIVES	DMS-6100
BITUMINOUS ADHESIVE FOR PAVEMENT MARKERS	DMS-6130
TRAFFIC PAINT	DMS-8200
HOT APPLIED THERMOPLASTIC	DMS-8220
PERMANENT PREFABRICATED PAVEMENT MARKINGS	DMS-8240

All pavement marking materials shall meet the required Departmental Material Specifications as specified by the plans.

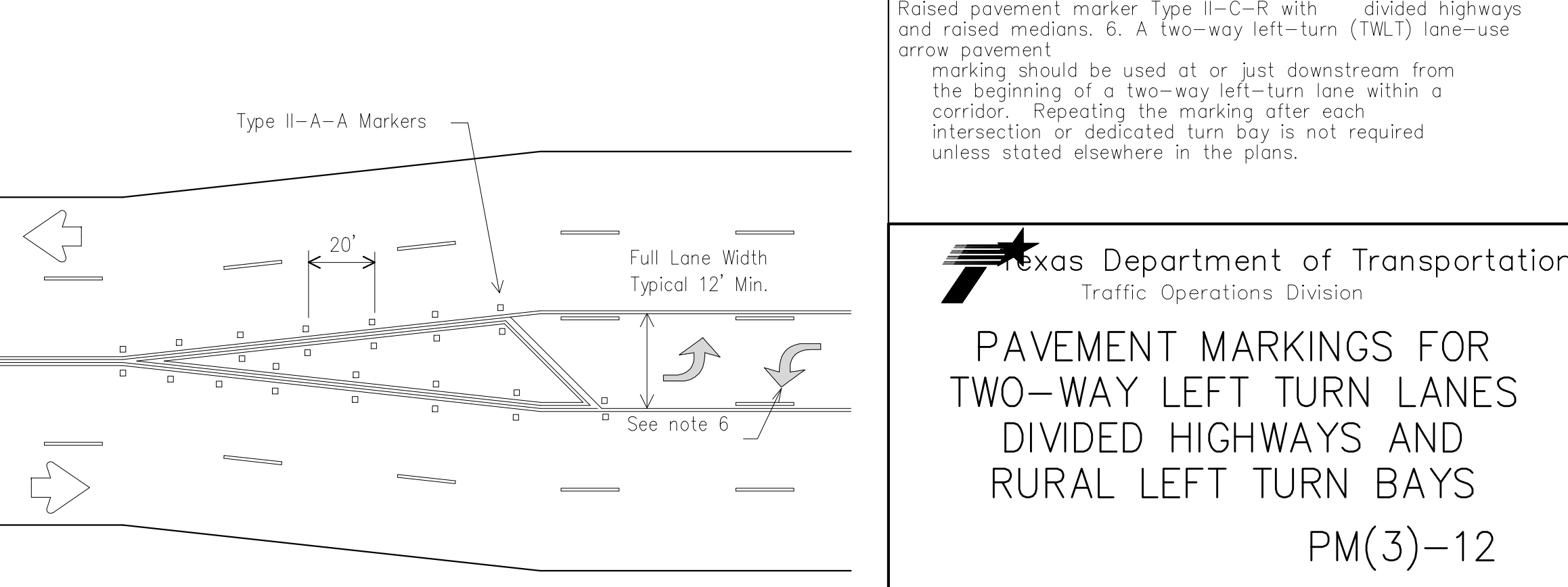

TYPICAL TRANSITION FOR TWLTL AND DIVIDED HIGHWAY

- GENERAL NOTES**
- Refer elsewhere in plans for additional RPM placement and details.
  - Lane use word and arrow markings shall be used where through lanes approaching an intersection become mandatory turn lanes. Lane use word and arrow markings should be used in auxiliary lanes of substantial length. Lane use arrow markings or word and arrow markings may be used in other lanes and turn bays for emphasis. Details for words and arrows as shown in the Standard Highway Sign Designs for Texas. 3. When lane used word and arrow markings are used, two sets of arrows should be used if the length of the bay is greater than 180 feet. When a single lane use arrow or word and arrow marking is used for a short turn lane, it should be located at or near the upstream end of the full-width turn lane.
  - Other crosswalk patterns as shown in the "Texas Manual on Uniform Traffic Control Devices" may be used.
  - Raised pavement marker Type I-C with undivided highways, flush medians and two way left turn lanes. Raised pavement marker Type II-C-R with divided highways and raised medians. 6. A two-way left-turn (TWLT) lane-use arrow pavement marking should be used at or just downstream from the beginning of a two-way left-turn lane within a corridor. Repeating the marking after each intersection or dedicated turn bay is not required unless stated elsewhere in the plans.

Texas Department of Transportation  
Traffic Operations Division

**PAVEMENT MARKINGS FOR TWO-WAY LEFT TURN LANES DIVIDED HIGHWAYS AND RURAL LEFT TURN BAYS**

PM(3)-12

© TxDOT April 1998		DN: TxDOT	CK: TxDOT	DW: TxDOT	CK: TxDOT
REVISIONS	CONT	SECT	JOB	HIGHWAY	
5-00 2-12					
8-00					
3-03					
2-10					
	DIST	COUNTY		SHEET NO.	

CITY OF SAN ANGELO  
ENGINEERING SERVICES  
CITY HALL ANNEX  
301 W. BEAUREGARD AVE.  
SAN ANGELO, TX 76903  
(325)657-4201  
www.cosatx.us



NO	DESCRIPTION	DATE

The Seal appearing on this document was authorized by Ricky L. Overstreet, P.E. 12/7/20 on March 31, 2020

ES-X-XX	TXDOT TSPM PM(3)-12	DRAWN BY: MG
	2020 GSB FRICTION SEAL	DESIGN BY: MG
	PROJECT NO: 2019-11-634	

SCALE: N.T.S.	DATE: 3/1/2020	ARCHIVE NO: #####	SHEET NO. C-004
---------------	----------------	-------------------	-----------------

DISCLAIMER: The use of this standard is governed by the "Texas Engineering Practice Act". No warranty of any kind is made by TxDOT for any purpose whatsoever. TxDOT assumes no responsibility for the conversion of this standard to other formats or for incorrect results or damages resulting from its use.

DATE:  
FILE:

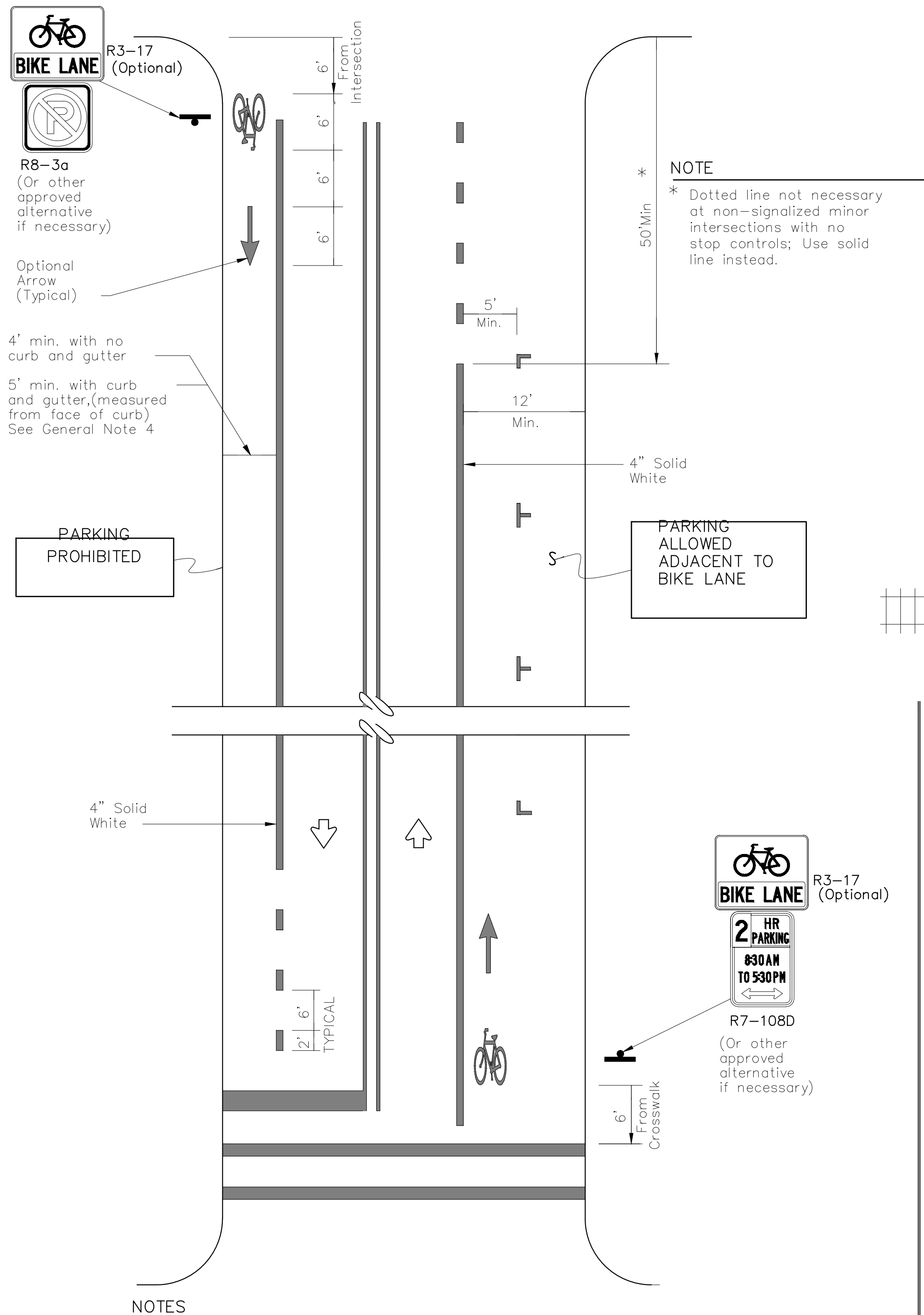

**NOTES**

1. Bicycle lane pavement markings typically repeated after each intersection or signalized driveway.
2. On uninterrupted sections of roadway, bicycle lane pavement markings typically repeated as follows:  
 -1200' for 45 MPH or less roads  
 -2500' for 50 MPH and greater roads.

**TWO-WAY STREET**

**GENERAL NOTES**

1. All bicycle lane pavement markings shall be white unless otherwise noted.
2. All pavement marking materials shall meet the required Department Material Specifications as specified by the plans.
3. Exact sign placement and details are shown elsewhere in the plans.
4. The current edition of AASHTO'S Guide for the Development of Bicycle Facilities should be referenced for variations in design, other geometric conditions, and lane width options.
5. Other bicycle lane symbol or word markings as shown in the Texas Manual on Uniform Traffic Control Devices may be used.
6. Details for words, arrows and symbols as shown in the Standard Highway Sign Designs for Texas.
7. The "BIKE LANE" (R3-17) sign with the "AHEAD" (R3-17a) sign mounted directly below should be installed in advance of the beginning of a marked bike lane.
8. The "BIKE LANE" (R3-17) sign with the "END" (R3-17b) sign mounted directly below should be installed at the end of marked bicycle lane.

**RAILROAD CROSSING APPROACH**

(See RCPM Standard for travel lane details)

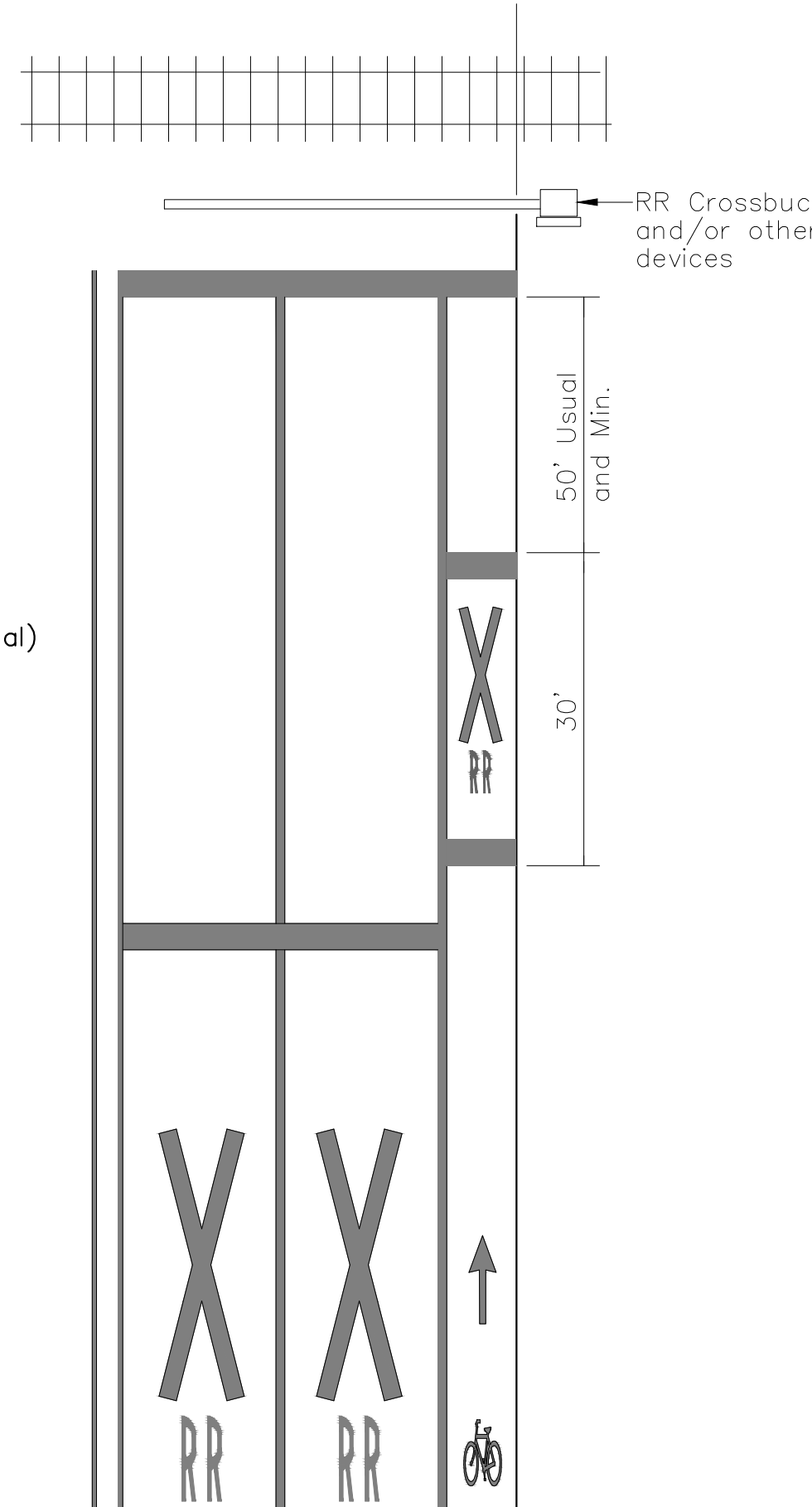

**RIGHT TURN ONLY LANE**

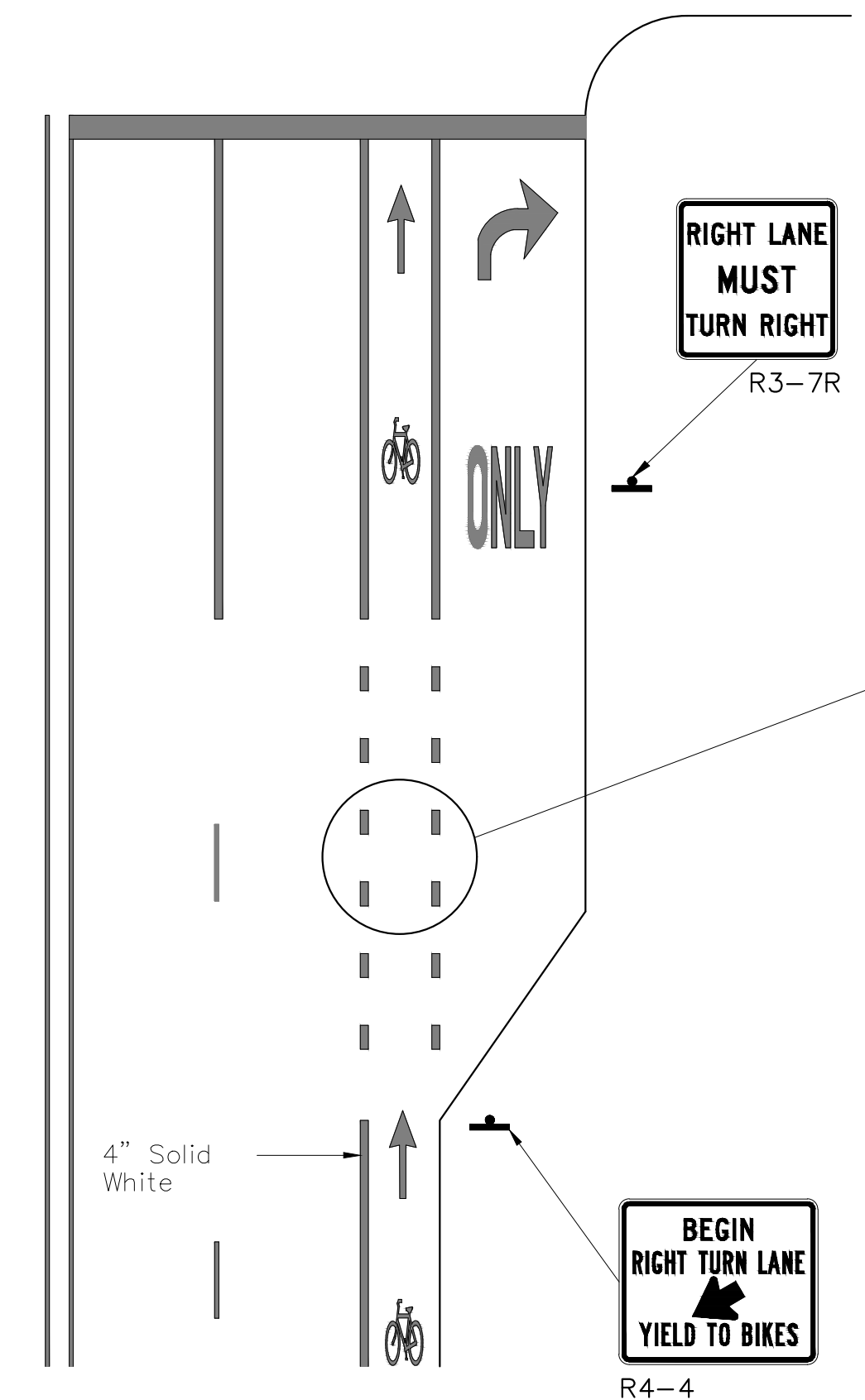

LEGEND	
	Sign
	Traffic Flow

SPECIFICATION REFERENCE TABLE	
Traffic Paint	DMS-8200
Hot Applied Thermoplastic	DMS-8220
Permanent Prefabricated Pavement Markings	DMS-8240
Glass Traffic Beads	DMS-8290

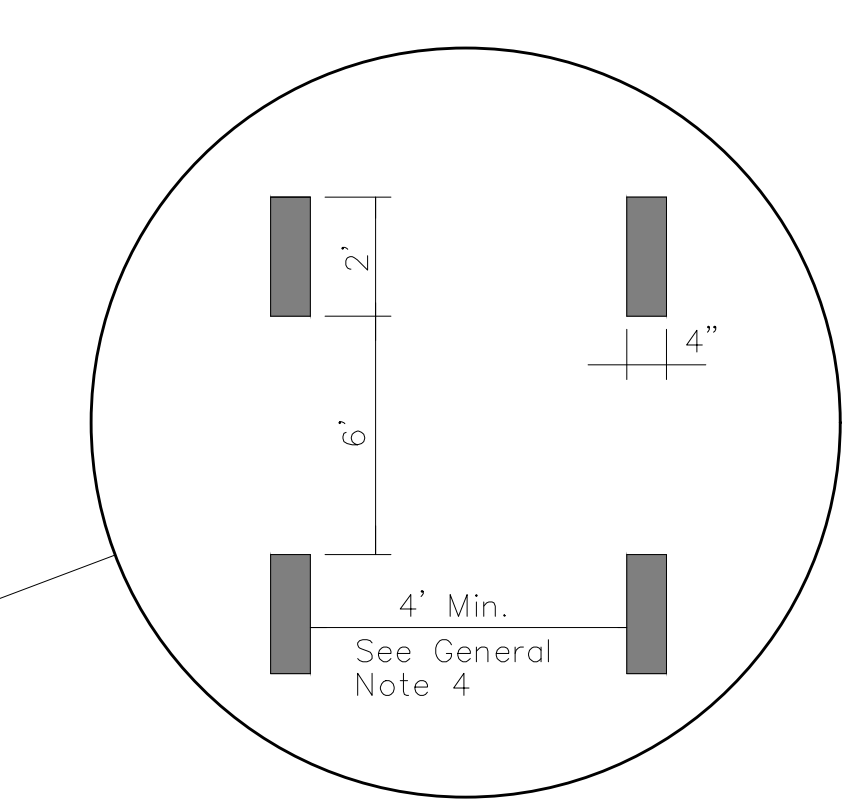

Texas Department of Transportation  
Traffic Operations Division

**BICYCLE LANE PAVEMENT MARKINGS**

**BLPM-10**

© TxDOT	May 2010	DN: TxDOT	CK: TxDOT	DW: TxDOT	CK: TxDOT
REVISIONS		CONT	SECT	JOB	HIGHWAY
		DIST	COUNTY		SHEET NO.

CITY OF SAN ANGELO  
ENGINEERING SERVICES  
CITY HALL ANNEX  
301 W. BEAUREGARD AVE.  
SAN ANGELO, TX 76903  
(325)657-4201  
www.cosatx.us



NO	DESCRIPTION	DATE

The Seal appearing on this document was authorized by Ricky L. Overstreet, E. 01782 on: 03/23/2020

ES-X-XX	TXDOT BLPM - 10	DRAWN BY: MG
	2020 GSB-FRICTION SEAL	
	PROJECT NO: 2019-11-634	
	DESIGN BY: MG	

SCALE: N.T.S.	DATE: 3/1/2020	SHEET NO. C-005
ARCHIVE NO: #####		

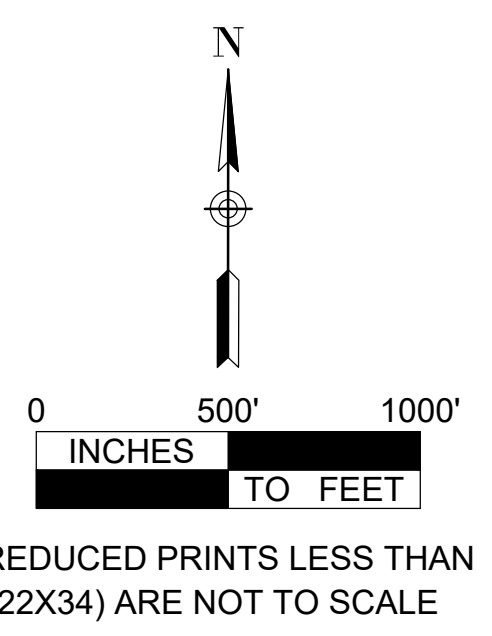
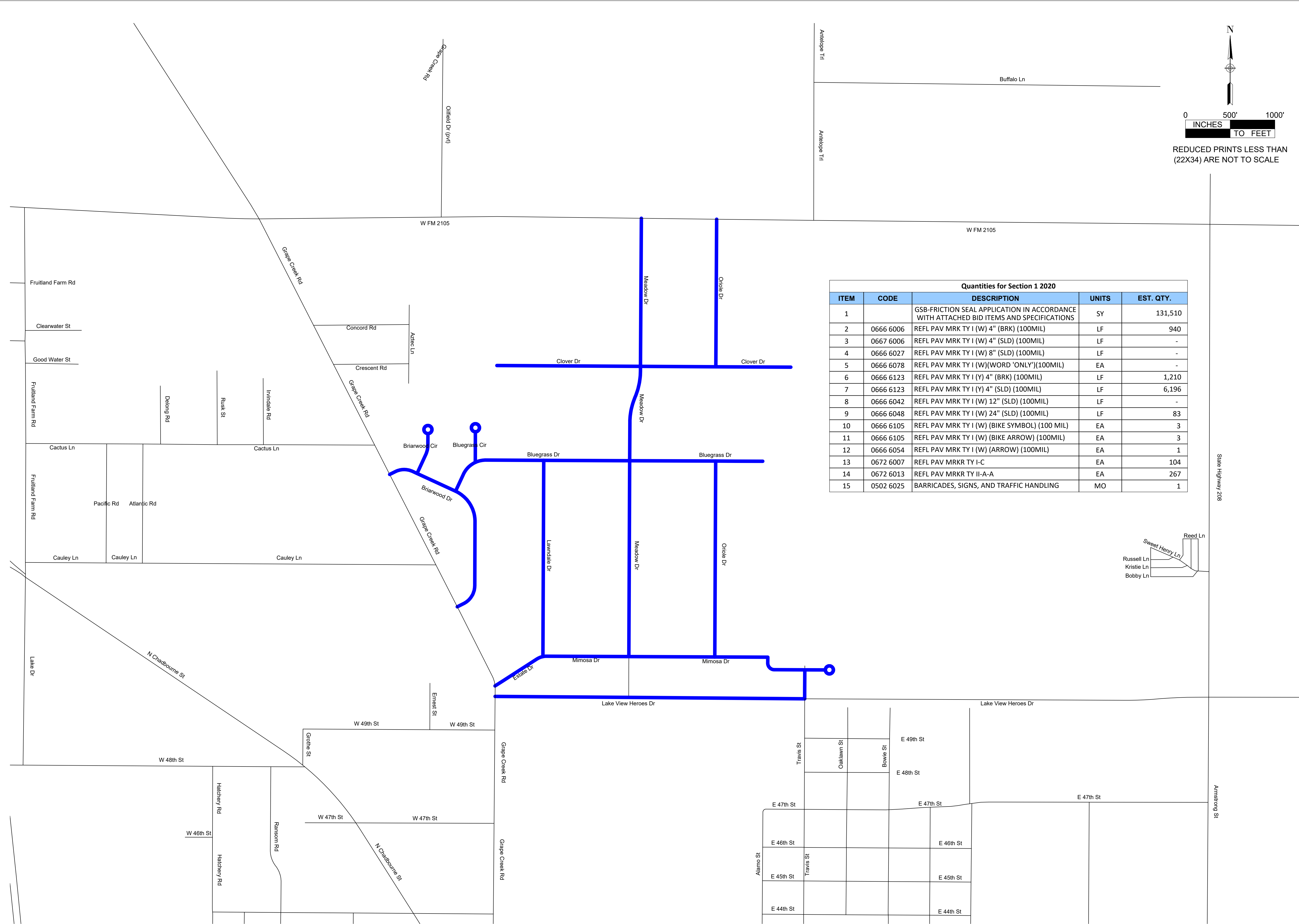

Quantities for Section 1 2020				
ITEM	CODE	DESCRIPTION	UNITS	EST. QTY.
1		GSB-FRICTION SEAL APPLICATION IN ACCORDANCE WITH ATTACHED BID ITEMS AND SPECIFICATIONS	SY	131,510
2	0666 6006	REFL PAV MRK TY I (W) 4" (BRK) (100MIL)	LF	940
3	0667 6006	REFL PAV MRK TY I (W) 4" (SLD) (100MIL)	LF	-
4	0666 6027	REFL PAV MRK TY I (W) 8" (SLD) (100MIL)	LF	-
5	0666 6078	REFL PAV MRK TY I (W)(WORD 'ONLY')(100MIL)	EA	-
6	0666 6123	REFL PAV MRK TY I (Y) 4" (BRK) (100MIL)	LF	1,210
7	0666 6123	REFL PAV MRK TY I (Y) 4" (SLD) (100MIL)	LF	6,196
8	0666 6042	REFL PAV MRK TY I (W) 12" (SLD) (100MIL)	LF	-
9	0666 6048	REFL PAV MRK TY I (W) 24" (SLD) (100MIL)	LF	83
10	0666 6105	REFL PAV MRK TY I (W) (BIKE SYMBOL) (100 MIL)	EA	3
11	0666 6105	REFL PAV MRK TY I (W) (BIKE ARROW) (100MIL)	EA	3
12	0666 6054	REFL PAV MRK TY I (W) (ARROW) (100MIL)	EA	1
13	0672 6007	REFL PAV MRKR TY I-C	EA	104
14	0672 6013	REFL PAV MRKR TY II-A-A	EA	267
15	0502 6025	BARRICADES, SIGNS, AND TRAFFIC HANDLING	MO	1

CITY OF SAN ANGELO  
ENGINEERING SERVICES  
CITY HALL ANNEX  
301 W. BEAUREGARD AVE.  
SAN ANGELO, TX. 76903  
(325)657-4201  
www.cosatx.us

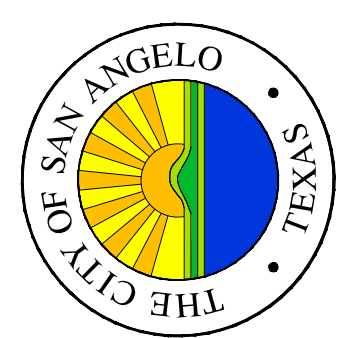

NO	DESCRIPTION	DATE

The Seal appearing on this document was authorized by Ricky L. Overstreet, P.E. 121782 on March 5, 2020

ES-X-XX  
**FRICTION SEAL - SECTION 1**  
 GREEN ACRES SUBDIVISION  
 PROJECT NO: 2019-11-634  
 DESIGN BY: MG  
 DRAWN BY: MG

SCALE: 1"=500'  
 DATE: 3/1/2020  
 ARCHIVE NO: #####  
 SHEET NO. C-400

Quantities for Section 2 2020				
ITEM	CODE	DESCRIPTION	UNITS	EST. QTY.
1		GSB-FRICTION SEAL APPLICATION IN ACCORDANCE WITH ATTACHED BID ITEMS AND SPECIFICATIONS	SY	45,590
2	0666 6006	REFL PAV MRK TY I (W) 4" (BRK) (100MIL)	LF	-
3	0667 6006	REFL PAV MRK TY I (W) 4" (SLD) (100MIL)	LF	-
4	0666 6027	REFL PAV MRK TY I (W) 8" (SLD) (100MIL)	LF	-
5	0666 6078	REFL PAV MRK TY I (W)(WORD 'ONLY')(100MIL)	EA	-
6	0666 6123	REFL PAV MRK TY I (Y) 4" (BRK) (100MIL)	LF	-
7	0666 6123	REFL PAV MRK TY I (Y) 4" (SLD) (100MIL)	LF	-
8	0666 6042	REFL PAV MRK TY I (W) 12" (SLD) (100MIL)	LF	-
9	0666 6048	REFL PAV MRK TY I (W) 24" (SLD) (100MIL)	LF	-
10	0666 6105	REFL PAV MRK TY I (W) (BIKE SYMBOL) (100 MIL)	EA	-
11	0666 6105	REFL PAV MRK TY I (W) (BIKE ARROW) (100MIL)	EA	-
12	0666 6054	REFL PAV MRK TY I (W) (ARROW) (100MIL)	EA	-
13	0672 6007	REFL PAV MRKR TY I-C	EA	-
14	0672 6013	REFL PAV MRKR TY II-A-A	EA	-
15	0502 6025	BARRICADES, SIGNS, AND TRAFFIC HANDLING	MO	-

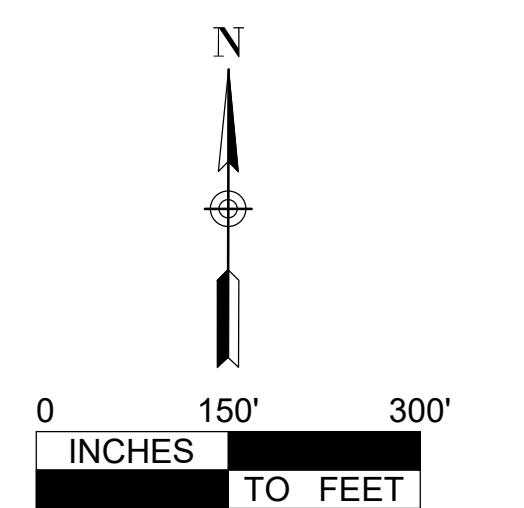
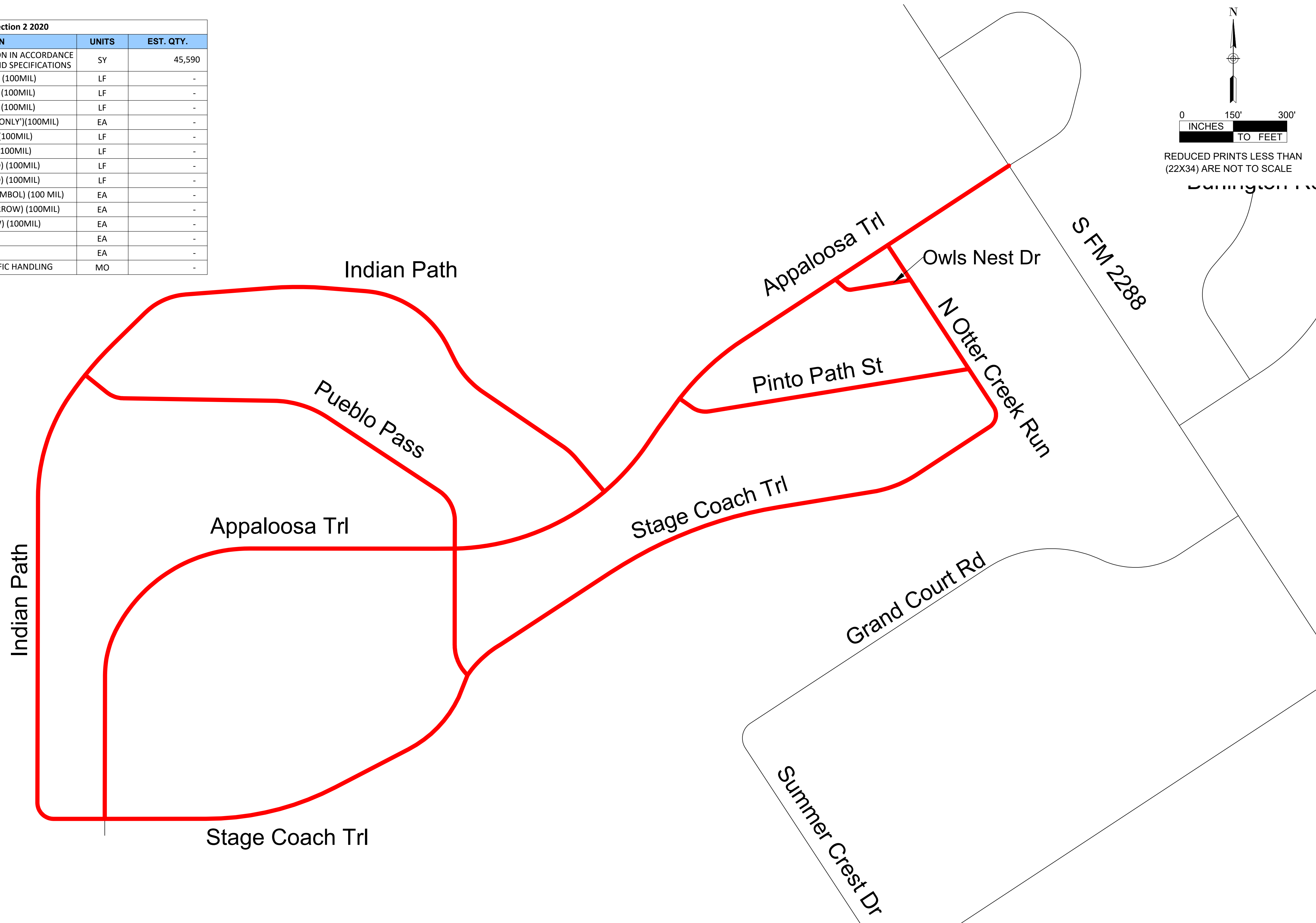

CITY OF SAN ANGELO  
ENGINEERING SERVICES  
CITY HALL ANNEX  
301 W. BEAUREGARD AVE.  
SAN ANGELO, TX. 76903  
(325)657-4201  
www.cosatx.us

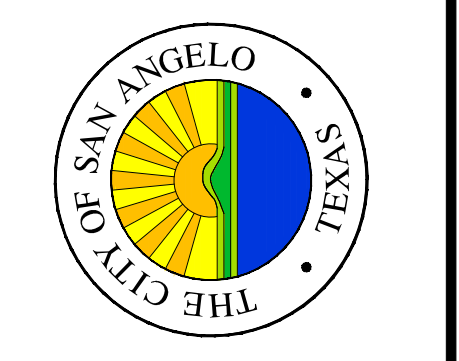

NO	DESCRIPTION	DATE

The Seal appearing on this plan is the property of the City of San Angelo, Texas and is not to be used without the written consent of the City of San Angelo, Texas.

By: *Ricky L. Overstreet*  
on: March 9, 2020

ES-X-XX  
FRICION SEAL - SECTION 2  
RIO CONCHO WEST ADDITION  
PROJECT NO: 2019-11-634  
DESIGN BY: MG  
DRAWN BY: MG

SCALE: 1"=150'  
DATE: 3/1/2020  
ARCHIVE NO: #####  
SHEET NO. C-401



Quantities for Section 4 2020				
ITEM	CODE	DESCRIPTION	UNITS	EST. QTY.
1		GSB-FRICTION SEAL APPLICATION IN ACCORDANCE WITH ATTACHED BID ITEMS AND SPECIFICATIONS	SY	17,130
2	0666 6006	REFL PAV MRK TY I (W) 4" (BRK) (100MIL)	LF	-
3	0667 6006	REFL PAV MRK TY I (W) 4" (SLD) (100MIL)	LF	1,973
4	0666 6027	REFL PAV MRK TY I (W) 8" (SLD) (100MIL)	LF	204
5	0666 6078	REFL PAV MRK TY I (W)(WORD 'ONLY')(100MIL)	EA	1
6	0666 6123	REFL PAV MRK TY I (Y) 4" (BRK) (100MIL)	LF	840
7	0666 6123	REFL PAV MRK TY I (Y) 4" (SLD) (100MIL)	LF	734
8	0666 6042	REFL PAV MRK TY I (W) 12" (SLD) (100MIL)	LF	-
9	0666 6048	REFL PAV MRK TY I (W) 24" (SLD) (100MIL)	LF	444
10	0666 6105	REFL PAV MRK TY I (W) (BIKE SYMBOL) (100 MIL)	EA	3
11	0666 6105	REFL PAV MRK TY I (W) (BIKE ARROW) (100MIL)	EA	3
12	0666 6054	REFL PAV MRK TY I (W) (ARROW) (100MIL)	EA	1
13	0672 6007	REFL PAV MRKR TY I-C	EA	4
14	0672 6013	REFL PAV MRKR TY II-A-A	EA	102
15	0502 6025	BARRICADES, SIGNS, AND TRAFFIC HANDLING	MO	-

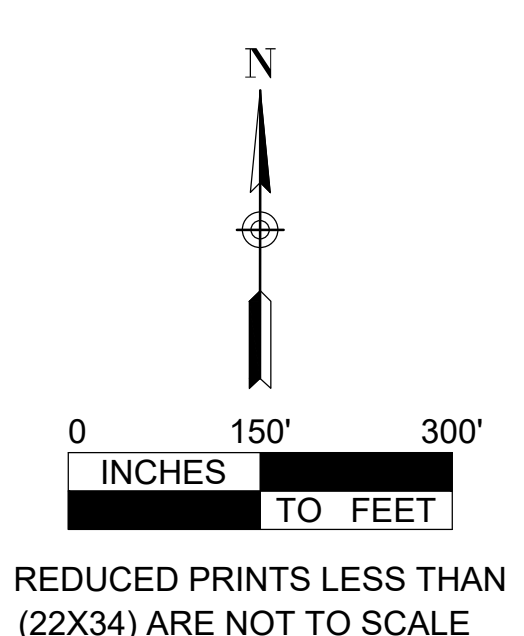

CITY OF SAN ANGELO  
ENGINEERING SERVICES

CITY HALL ANNEX  
301 W. BEAUREGARD AVE.  
SAN ANGELO, TX. 76903  
(325)657-4201  
www.cosatx.us

NO	DESCRIPTION	DATE

The Seal appearing on this document was authorized by Ricky L. Overstreet, P.E. 121782 on March 5, 2020

ES-X-XX	FRICTION SEAL - SECTION 3	DESIGN BY: MG	DRAWN BY: MG
	E. 14TH FROM CHADBOURNE TO MAIN		
	PROJECT NO: 2019-11-634		

SCALE: 1"=150'	DATE: 03/01/2020	ARCHIVE NO: #####	SHEET NO. C-402
----------------	------------------	-------------------	-----------------